

LOW COST SLAB MANUFACTURED FROM MASONRY SLAB ELEMENTS

John K. Makunza

Department of Structural Engineering, University of Dar es Salaam,
P. O. Box 35131 Dar es Salaam, Tanzania

The construction of bungalow houses requires sufficient space to accommodate all the requirements as per the client's wish. The idea of low-rise or high rise buildings is very remote for most of the people due to the high costs of construction involved. Much of the said cost is due to the concrete floor slab as it consumes a bigger portion of concrete material when compared to beams and columns. In this paper, a study presented is on a new form of voided slab constructed from masonry slab elements that do not utilize formwork and consumes less concrete material. The slab is composed of slab strips made from masonry slab elements, which are prepared on ground and after developing sufficient strength are then manually lifted and placed in position of the slab. It has been observed that the strength of the hollow slab is equal to the solid concrete slab, and the associated cost of this new type of slab is only 60% of the solo solid concrete slab. Hence, low-rise building can be constructed at low cost with advantages of saving space and positive environmental effect as less or no trees are felled for shuttering purposes.

Keywords: Slab elements, slab strips, strength, design, low cost

INTRODUCTION

The construction of big and medium bungalow houses in urban and rural areas utilize substantially big plan areas. For example, if a certain bungalow house occupying an area of say 100m^2 in plan view, having 4 bed rooms, a kitchen, dining area, 3 toilets/baths and a garage, would be arranged in such away that some rooms; e.g. all 4 bedrooms be placed in the first floor. This would reduce the occupied plan area from 100m^2 to say 60m^2 saving 40m^2 for other purposes or left as an open-to-sky area. For example Figure 1 shows a common bungalow house found in most parts of Tanzania. A thorough observation of this floor plan portrays that the area covered by $L2 \times W$ can be placed on the 1st Floor over the part of house with length $L1$. Hence the area $L2 \times W$ would be saved or used for other purposes. The cost of the foundation and roof for this part of house

covered by the area $L2 \times W$ would be nearly equal to or less than the cost of the new hollow slab form idealised in this study.

The construction of upper floors using solo concrete slabs is expensive and so less affordable by the majority of people especially in developing world, as it requires high expertise, timber shuttering, cranes and vibrators among others. This problem leaves many people with only one option of building bungalows, even if the cost would be the same as for a two stories house because there is no any information on how one can construct an affordable low-rise house at a reduced cost item.

In order to solve the problem and/or reduce the cost item, a new form of slab construction that is simple but meets the functional requirements is needed. For this reason, an idealisation of the slab strips which are manufactured from a series of horizontally laid hollow blocks of the shape

shown in Figure 2 has been made. The lifting of the slab strips can be done manually by an average of one person per every 0.5 m run.

not utilize formwork by using masonry slab elements, steel reinforcement, mortar [EC-6; 2000] and less amount of concrete in comparison to the solo concrete slab.

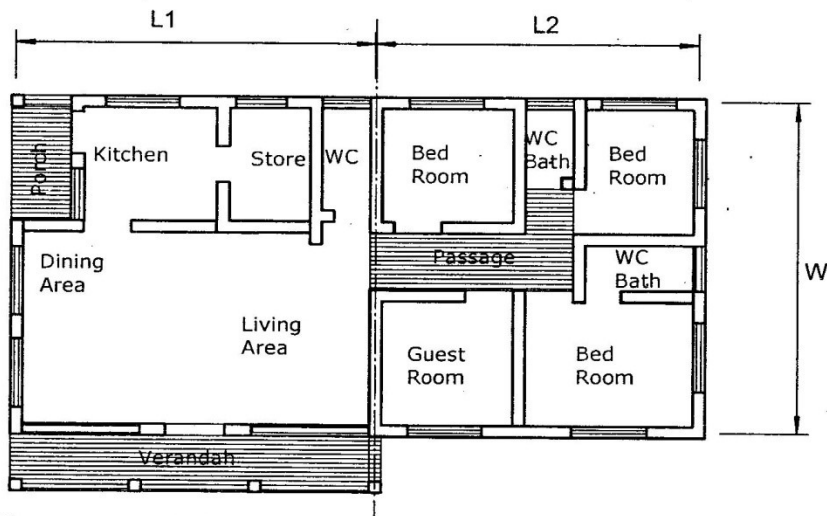
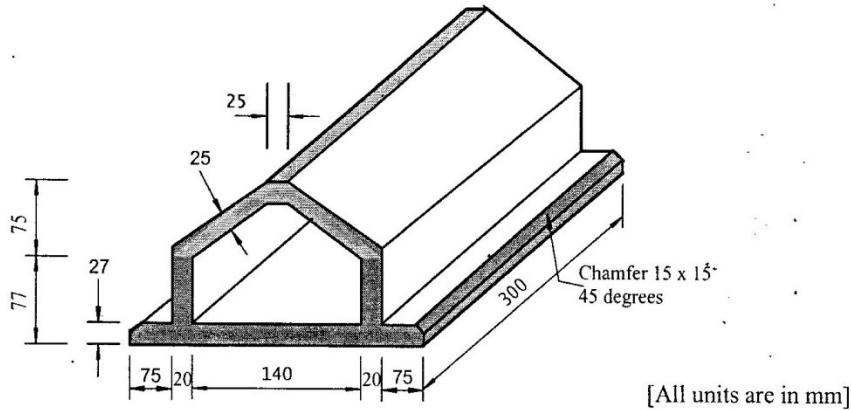
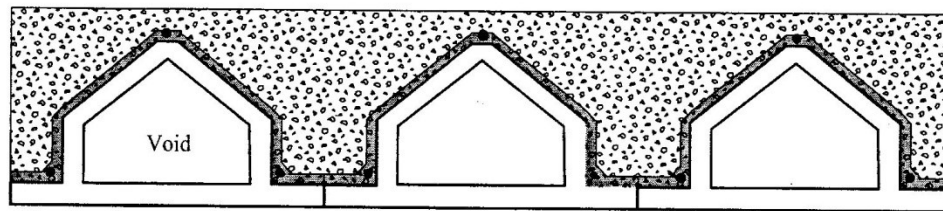

Figure. 1 Typical bungalow



[All units are in mm]

Slab element

Figure. 2: Slab elements

OBJECTIVES OF THE STUDY

The objective of the study is to develop a simple and cheaper way of slab construction which does

METHODOLOGY OF THE STUDY

The research study was carried-out by implementing the following activities:

- Design configuration of the masonry slab elements
- Production of drawings for the elements
- Design of the mould followed by drawing and manufacturing of the mould
- Slab elements production
- Building of the slab strips
- Casting of solid slab strips for comparison purposes
- Testing of the slab strips
- Assembling of slab strips to form slab panels and pouring of concrete

THE LOW-COST SLAB

The low cost slab is called so because it utilises no timber form-work, requires less concrete and is simple in construction and can be lifted up manually. The production of the said slab elements involves a number of steps as indicated in the subsequent sub-headings.

MOULD PRODUCTION

The mould for manufacturing the slab elements was made of hard wood (“Mninga”) so as to minimize the water absorption and have a loose bond between cement mortar and the timber surface. The thickness of the timber was 25mm. The height of the mould was 300mm. Other mould membrane and parts are as shown in Plate

1. The inner surfaces of the mould membranes were anointed with oil in order to prevent any bond between the moist mortar and the hard wood surface.

MANUFACTURING OF SLAB ELEMENTS

The slab elements were manufactured using the already prepared timber mould (see Plate 1). The process of manufacturing started with batching the respective materials; viz; sand and cement.

The ratio of the materials by volume is 1:8 (1 part cement by 8 parts sand) in which 1 bag of cement produced around 30 elements. The sand used had the same properties like the one used for reinforced concrete in which it was free from silt. The materials were then thoroughly dry mixed, after which water was added and the mixing continued till when the mortar was squeezed in the hand, it didn't break. Such property was achieved when the water cement ratio was in the range of 0.30 to 0.35. The mixed mortar must appear to be like moist ash-sand, that even when handled in hand-palm, no water shall be observed in the hand.

The moist mortar was then filled in the mould in at least three stages. The first fill covered up to around two-thirds of the mould height, then it was compacted by ramming using a timber rod which has less thickness than that of element

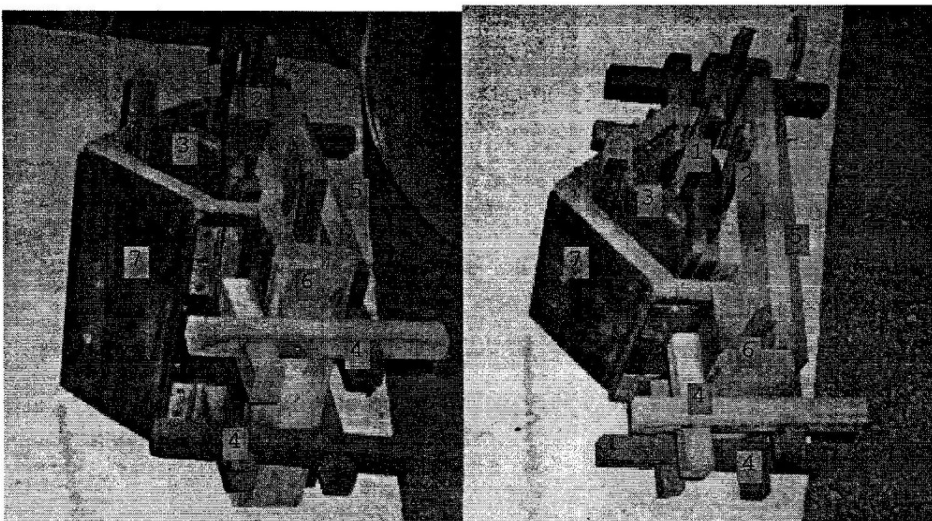

Plate 1: Timber mould

membranes so as to allow for effective compaction. At least, every position of the element should be compacted.

When one layer was already compacted, the fill was repeated and compacted again till the mould was filled and compacted to the brim. Then the mould removal was done step by step by loosening and taking away the mould parts as shown in Plate 1 numerically.

After 24 hours, the slab elements were sufficiently hard and were cured in water for 7-days, then left in air for 4 days after which they were ready for construction of slab strips.

PRODUCTION OF SLAB STRIPS

The slab elements were joined together with cement mortar of a mix ratio of 1:6 by volume as seen in Plate 2 below.

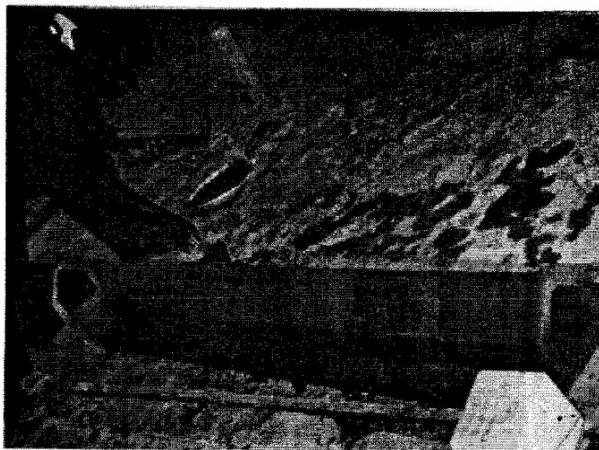
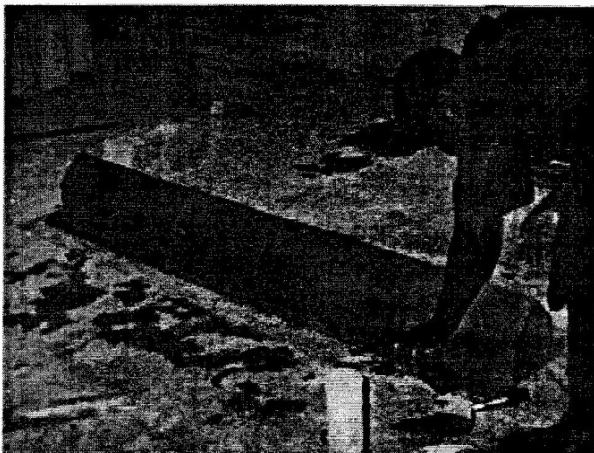

Plate 2: Joining of slab elements

Then suitable reinforcement of Y10 or Y12 depending on the design span, were placed along AB (ref. Fig. 3) on both sides of the slab element, after which plastering was done to the vertical sides of the slab element only. The thickness of the plaster was approximately 15 to 20mm on the sides. The ratio of the mix was 1:4 (1 part of cement by 4 parts of sand). The mortar of this grade was purposely used to enhance higher strength as it bonds well with the reinforcement.

The appearance of the slab strip was as depicted in Figure 3(a) for un-plastered and Figure 3(b) for plastered strips.

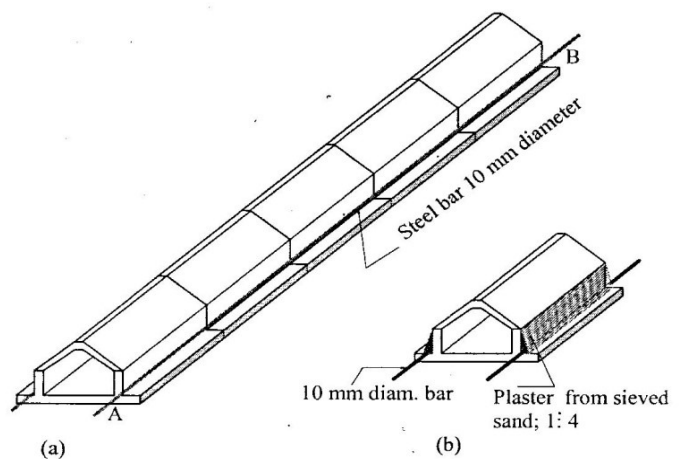

Figure. 3. Slab strips; (a) after joining the slab element; (b) after plastering



Plate 3: Plastered and hardened slab strips, lifted and arranged to form a slab panel

After the slab strip had been cured and hardened for 14 days, it could be lifted up by an average of 2 people per 1m length.

The designated maximum length for the size of slab elements studied in this case was around 4.0m, and so only 8 people for lifting it up in order to place in position were required.

CONSTRUCTION OF THE SLAB

Once the slab strips are constructed and cured for at least 7 days, they can be lifted up and placed in position to form the required width and length of the slab. The slab strips are placed side by side till they cover the whole slab panel. Then concrete of the required grade is poured to form concrete ribs and topping membrane of around 30 mm thick. The process of construction is illustrated in Plate 5.

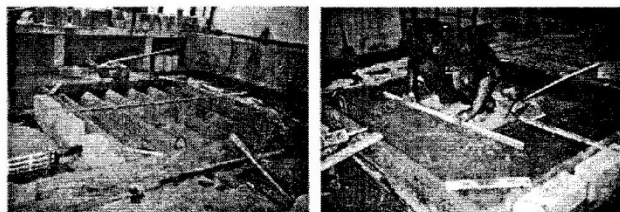

Plate 5: Slab panel construction using slab strips

THEORETICAL DESIGN APPROACH

General

The design of slabs is carried by idealizing the slabs into smaller strips of 1.0m, along the span in consideration. From there, using the methods of coefficients [BS 8110, 1985] or Crapeyron Equation [DIN 1045, 1988], moments and shears

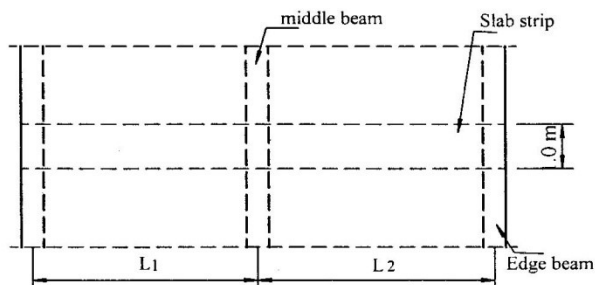

Figure 4: Slab idealized into strips

at the supports can be determined as well as span moments.

If the ratio of the longer span to the shorter span of the slab panel is less than 2, the slab panel is said to be a two way-slab, otherwise it is a one-way slab.

If the acting dead load to the slab is denoted by G_k , and the live load denoted by Q_k [EC-2, 2000] per square metre, the design load at ultimate limit state is given by:

$$n = \gamma_{fg}G_k + \gamma_{fq}Q_k \text{ [kN/m}^2 \text{]} \quad (1)$$

where γ_{fg} and γ_{fq} are partial factors of safety for dead and live loads respectively.

Hence, for a strip of 1.0m width, the design load is; (1.n), expressed as:

$$n \text{ [kN/m]} \quad (2)$$

In all forms of slabs such as, Solid slabs, Ribbed slabs and Waffle slabs, the design process includes idealization of the slab into appropriate strip widths depending on the guides given in the design codes, e.g. BS 8110, Part 1 [BS 8110, 1985, 1997]. Using the obtained internal actions, the amount of steel reinforcement in the slab can be designed and provided.

The New Slab Element Strips

To simplify the analysis, the slab strip indicated as Slab strip 1 in Figure 5 is taken into consideration. It can be seen that both Slab strips 1 and 2 have the same amount of concrete necessary for resisting the forces induced by the self weight as well as external loads.

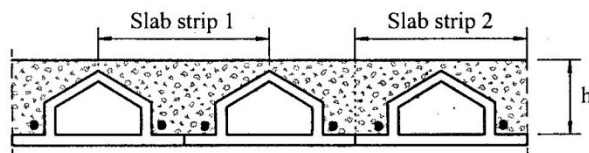

Figure 5: Slab strips

In Figure 6, slab strip 1 is depicted in order to study the stress distribution in the section of the strip.

With reference to Figure 6, and limiting the neutral axis depth to the start of the incline of T-section, the following notations are depicted;

F_{C1} = force due to the topping concrete which has a thickness of h_f and breadth b .

F_{C2} = force due to the concrete just below the topping to the neutral axis with width b_w

and height $x - h_f$

F_{C3} = force due to the triangular area of concrete with width b_f and height $x - h_f$

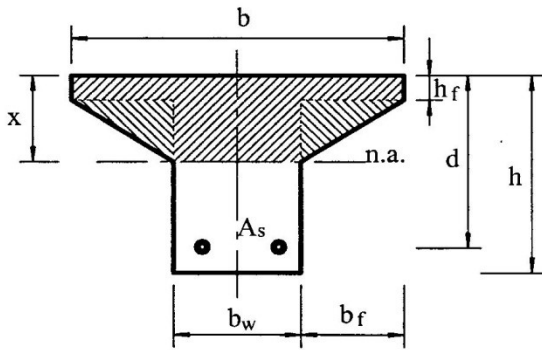

Figure 6: Stress distribution in the slab strip

F_s = tensile force due to the reinforcement

The above concrete compressive forces can now be expressed in mathematical models as follows:

$$F_{C1} = 0.447f_{cu} \cdot b(h_f) \quad (3)$$

where f_{cu} = characteristic strength of concrete

$$F_{C2} = 0.447 f_{cu} b_w (0.9x - h_f) \quad (4)$$

$$F_{C3} = 0.447f_{cu} \cdot \frac{1}{2} (b - b_w)(0.9x - h_f)/2 \quad (5)$$

$$F_s = 0.87f_y A_s \quad (6)$$

Where f_y = characteristic strength of steel reinforcement

A_s = area of steel reinforcement

For equilibrium ($\Sigma F_H = 0$),

therefore ;

$$F_s = F_{C1} + F_{C2} + F_{C3} \quad (7)$$

$$0.87f_y A_s = 0.45f_{cu} [(h_f b + b_w(0.9x - h_f) + \frac{1}{2}(b - b_w)(0.9x - h_f)/2)].$$

The effective depth is needed for facilitating the calculation of the lever arm as well as moment of resistance, and is given by the expression;

$$d = h - c - \phi/2 \quad (8)$$

On determining the respective lever arms, the moment of resistance, M_{rc} , with respect to concrete is therefore equal to:

$$M_{rc} = 0.447f_{cu}[h_f(d - h_f/2) + b_w(0.9x - h_f) + (d - h_f - (0.9x - h_f))\frac{1}{2}(b - b_w)/2] \quad (9)$$

For the particular form of slab element studied,

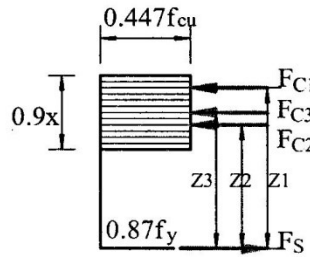

the following were the values of the variables;

$b = 330\text{mm}$, $x = 100\text{mm}$, cover = 15mm, $b_w = 150$, ϕ of bar = 10 mm, $h_f = 25$ mm

$h = 150\text{mm}$, $f_{cu} = 20\text{N/mm}^2$, $f_y = 250\text{N/mm}^2$

Using the data above and Equation (9), the moment of resistance of the section was determined and found to be: $M_{RC} = 8.83 \text{ kNm}$

Analysis due to External Loads

The following loads were assumed with respect to design of normal reinforced slabs:

Density of concrete = 24.0 kN/m^3

Load due to floor finishes = 2.0 kN/m^2

Load of tiles = 1.5 kN/m^2

Live load (CP 3) = 3.2 kN/m^2

Total dead load including the slab strip self weight was found to be; $g_k = 1.89 \text{ kN/m/strip}$, while the imposed load; $q_k = 3.2 \times 0.33 = 1.10 \text{ kN/m/strip}$.

Using the respective partial safety factors for dead and live loads, the design load was calculated, thus:

$$\text{Design load, } n = 1.4(1.89) + 1.6(1.1) = 4.41 \text{ kN/m/strip}$$

The design moment is therefore equal to:

$$M = \frac{nL^2}{8} = \frac{4.41}{8} L^2$$

Since $M_{max} = M = M_{RC}$. The maximum span for the slab strip was determined by solving the expression;

$$8.83 \text{ kN/m} = (4.41)L^2/8,$$

in which the maximum span was found to be, $L = 4.00 \text{ m}$. The obtained L, shall be the shorter span length of the slab panel; traditionally denoted as L_x .

strips were conducted in order to assess their suitability for slab construction. The tested slab strips were of 1.95 m effective span between the supports and the width was 330 mm so that at least 3 strips make one metre width. There were 6 slab strips built from the hollow slab elements and 3 solid slab elements for comparison purposes. All of them were cast from the same batch of concrete. The age of specimens at the day of test were 2 months. The test was done at the Structures and Building Materials Laboratory-University of Dar es Salaam.

Plate 4 shows some of the tested slab elements in which the two top pictures illustrate the diagonal shear failure of the hollow slab strips. The two bottom pictures in Plate 4 illustrate the crack pattern of the slab strips where by the left one is for the solid slab strip while the right hand one is for the hollow slab strip.

TESTS ON SLAB ELEMENTS AND SLAB STRIPS

Tests on the *slab elements* as well as the slab

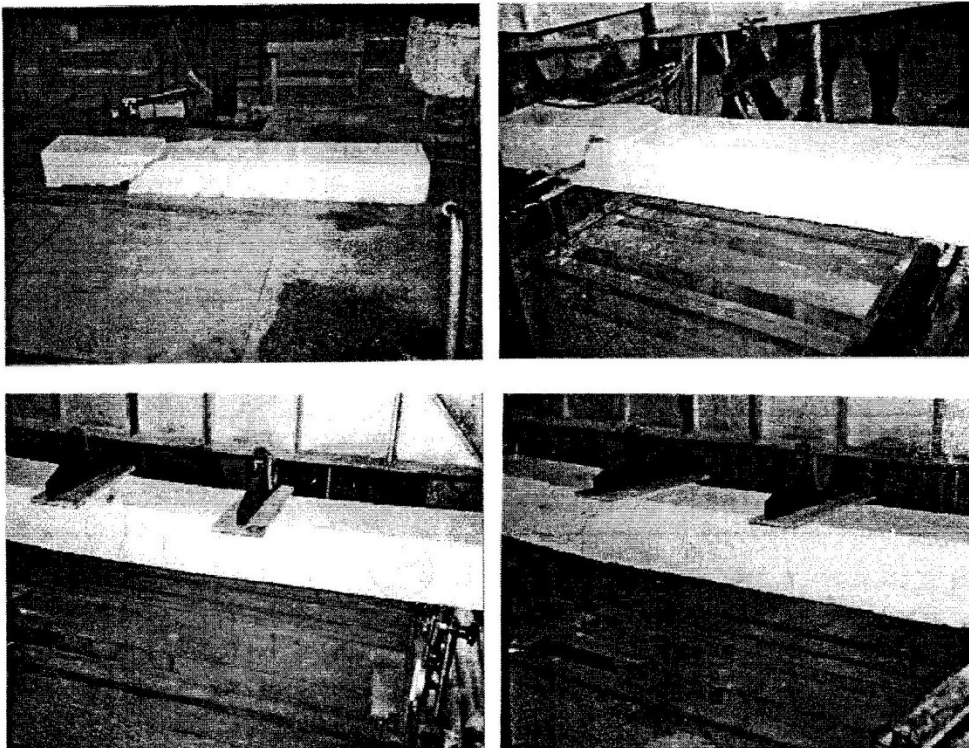

Plate 4: Test on slab elements (top pictures – failure mode of hollow strips, bottom pictures; crack pattern: left - solid strips, and right – hollow strips)

RESULTS

The obtained results are summarised in Table 1.

For some of the specimens, deflections against loads were taken at load incremental of 5 kN steps, and the results are shown in Table 2.

A graph for load – displacement curves for the slab strips is shown in Figure 7, thus;

The solid slab strips failed by crushing near the centre of the strips. This indicates that the concrete crushed in compression zone after failing in the tension zone.

Regardless of the failure modes, the failure loads for the hollow slab strips and solid slab strips are almost equal as seen in Table 1. The average failure load for the hollow slab strips is 47.08 kN and for solid slab strips is 43.83 kN.

Table 1. Slab strips test results

Sample No.	1 st Crack load (kN)	Failure load (kN)	Remarks	Remarks	
ST1	31.5	50.5	Shear failure		
ST2	24.5	48.5	Shear failure		
ST3	19.5	42.0	Shear failure	Hollow slab strips	
ST4	17.5	46.0	Shear failure		
ST5	16.0	52.5	Shear failure		
ST6	16.0	43.0	Shear failure		
SS1	23.5	50.5	Crushing at centre		Solid slab strips
SS2	20.0	48.5	Crushing at centre		
SS3	19.0	32.5	Crushing at centre		

Table 2. Deflections of specimens during testing

Force kN	Slab strip ST4	Slab strip ST5	Slab strip ST6	Solid Slab SS2	Solid Slab SS3
	Deflection mm	Deflection mm	Deflection mm	Deflection mm	Deflection mm
0	0.00	0.00	0.00	0.00	0.00
5	0.25	0.30	0.20	0.23	0.20
10	0.83	0.90	1.10	0.52	0.42
15	1.90	2.00	2.20	1.12	1.00
20	2.15	3.10	3.50	3.20	2.90
25	3.45	4.30	4.50	4.75	3.30
30	4.30	5.50	5.70	6.50	4.85
35	6.42	6.90	7.10	9.80	6.53
40	8.85				
45	10.20				

DISCUSSION ON THE RESULTS

From the obtained results, it has been observed that all hollow slab strips had a shear diagonal failure pattern which took place close to one support. This phenomenon happened in such a manner because the hollow strip had smaller areas of shear in comparison to the solid strips.

For the first crack loads of the hollow strips; 3 values are higher than the corresponding values of the solid slab strips, while the other 3 values are below the values of the solid strips. The average first crack load for the solid slab strips is 20.83 kN, also this average value is the same for the hollow slab strips. This shows that strength-wise, the difference between the two forms of the slab strips is negligible; i.e they are equal.

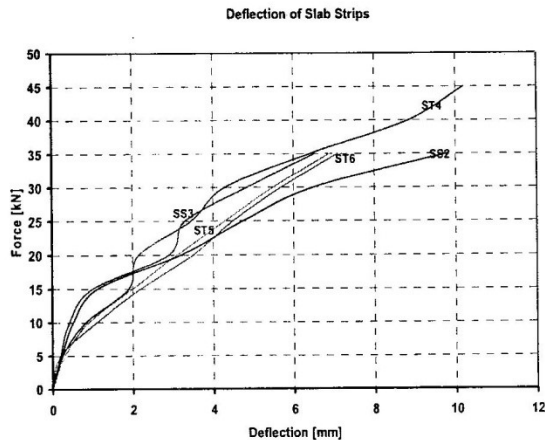

Figure. 7. Deflection of Slab strips

Deflections of 3 hollow strips and 2 solid slab strips presented in Table 2 and in Figure 7 show that up to a load of 5.0 kN the value of the deflection was just the same having an approximate value of 0.25mm. The solid specimens were much more stable for they uniformly deflected to about 2mm at 7 kN load, while at the same load, the hollow slab strips reached values of around 3mm. When the deflection reached 6mm, one solid specimen had reached a load of 33 kN while the other solid

specimen reached a load of 28 kN. The hollow strips at 6mm deflection reached load values of 34.0 kN, 32.0 kN and 31.5 kN respectively.

Slab elements ST4 and SS2 deflected to around 10mm with corresponding loads of 44.0 kN and 35.0 kN respectively. From the graph in Figure 7, it is evident that no trend of deflection can be established because the values are randomly distributed for both solid strips as well as hollow strips.

COST ANALYSIS

Since the hollow slab strips utilizes masonry elements and concrete without any form-work, it implies that there is a reduction in the cost item. The amount of materials for a 4.0 m x 4.0 m hollow slab in contrast with the solid slab strip are shown in Table 3.

From the analysed quantity of materials above it is observed that the amount of reinforcement for both types of slab strips is equal. The amount of concrete material utilized by the hollow strips is less than that of the solid slab strips; it is approximately 62 % of the amount in the solid strips. It is also noted that the hollow slab strips utilize masonry elements instead of timber formwork.

Table 3. Material quantities

Material description	Hollow slab	Quantity	Solid slab	Quantity
1. Masonry elements	yes	147	none	-
2. Steel bars	yes	59.14 kg	yes	59.14 kg
3. Concrete (1:2:4)	yes	13.76 m ³	yes	22.2 m ³
4. Form-work	none	-	yes	16 m ²

Table 4 Cost comparison

A. Hollow slab made of slab strips manufactured from masonry elements					
No.	Item description	Quantity	Unit	Rate; TShs	Cost; TShs
1	Masonry elements + mortar	147.00	pcs	500	73,500
2	Steel bars of 10 mm diameter	60.00	kg	1,200	72,000
3	Concrete (1:2:4 mix)	13.76	m ³	130,000	1,788,800
4	Form-work	-	-	-	-
TOTAL (A)					1,934,300
B. Solid slab					
1	Masonry elements + mortar	-	-	-	-
2	Steel bars of 10 mm diameter	60.00	kg	1,200	72,000
3	Concrete (1:2:4 mix)	22.20	m ³	130,000	2,886,000
4	Form-work	16.00	m ²	15,000	240,000
TOTAL (B)					3,198,000

The cost comparison between the two slab systems is depicted in Table 4.

With respect to the amounts of materials for each form of the slab strips, the respective costs for the studied elements which cover a slab panel of about 4.0 m x 4.0 m shows that the hollow slab constructed from masonry elements is TSh 1,934,300/=, while the cost of concrete solid slab is TShs 3,198,000/=. In comparison, it is seen that the hollow slab is about 60% of the cost of concrete solid slab.

CONCLUSIONS AND RECOMMENDATIONS

From this study, it is concluded that a hollow slab constructed from masonry elements is a feasible solution leading to low cost house system. The construction of the slab is simple, cheaper in cost and is a labour based construction as it needs no cranes or sophisticated equipment for lifting up.

The strength of the hollow slab constructed from masonry elements is almost equal to the solid slab.

From the cost analysis, it is concluded that the cost of the hollow slab constructed from masonry element is about 60% of the solo concrete solid slab.

It is therefore recommended that the hollow slab constructed from slab strips made from masonry elements be used in building low cost houses.

It is further recommended that other slab elements from clay be studied. This can reduce the cost further and make the slab more affordable by more people especially in rural areas.

ACKNOWLEDGEMENTS

The financial support for this study was provided by the African Institute For Capacity Development (AICAD). The author pays special gratitude for the support received.

REFERENCES

1. BS 8110, Part1, 1985; Structural Use of Concrete
2. BS 8110, Part1, 1997; Structural Use of Concrete
3. BS 6399, Part 1, 1984; Code of Practice for dead and live loads.
4. CP 3, Chapter V, Live loads
5. EC-2, Euro Code No. 2, Design of Concrete Structures
6. EC-6, Euro Code No.6, Design of Masonry Structures
7. DIN 1045, 1988; Beton und Stahlbeton, Bemessung und Ausführung, Juli; 1988.