

Full Length Research Paper

Deconvolution of Mono-Energetic and Multi-Lines Gamma-Ray Spectra Obtained with NaI(Tl) Scintillation Detectors Using Direct Matrix Inversion Method

Mwingereza J. Kumwenda

Department of Physics, University of Dar es Salaam, Tanzania
Corresponding author: kmwingereza@udsm.ac.tz

ABSTRACT

Performance of a NaI(Tl) scintillation detector based on the gamma-ray spectroscopy system is not satisfactory in retaining its original peak (which is delta like function) of various gamma ray spectrum. The method of achieving precise peak for the various gamma ray was conducted by converting the observed pulse-height distribution of the NaI(Tl) detector to a true photon spectrum. This method is obtained experimentally with the help of an inverse matrix deconvolution method. The method is based on response matrix generated by the Monte Carlo simulation based on Geant4 package of mono-energy gamma-ray photon ranging from 0.050 to 2.04 MeV in the interval of 10 keV. The comparison of the measured and simulated response function was also performed in order to authenticate the simulation response function. Good agreement was observed around the photo-peak region of the spectrum, but slight deviation was observed at low energy region especially below 0.2 MeV. The Compton backscattering and Compton continuum counts was significantly transferred into the corresponding photo-peak and consequently the peak to total(P/T) ratio was improved. The P/T ratio results obtained after application of the deconvolution method taken with three calibration sources with gamma-ray's energies of 81 keV, 303 keV and 356 keV (for ¹³³Ba), 662 keV (for ¹³⁷Cs), 1173 keV and 1333keV (for ⁶⁰Co), were improved from(to) 0.50(0.90), 0.40(0.83), 0.57(0.93), 0.31(0.92), 0.18(0.84) and 0.15(0.83), respectively.

Keywords: NaI(Tl) detectors, Deconvolution/Unfolding, Response function, Gamma-ray spectrum, Geant4 simulation

INTRODUCTION

The main characters of gamma ray spectra are associated with the process by which gamma rays interact with matter. However, the events with energy less than full energy occur rather frequently, resulting from various interactions with different energy dependences. In gamma ray spectroscopy, it is necessary to know the true photon energy spectra of the NaI(Tl) scintillation detector. Without application of unfolding methods,

incorrect physical data are obtained from an analysis of the measured gamma ray spectra (Arvind *et al.*, 2008). To determine the correct photon energy spectra from the recorded pulse height distributions one need to apply the unfolding technique.

The technique of converting the pulse height distribution to the true photon's spectrum has been studied previously by several literatures (Hanka, 2020; Kiran *et al.*, 2016; Morhac and Matousek, 2011). While the general principles on which the

technique is based are the same, these literatures claim varying degrees of success for different method of approach (Hanka, 2020; Kiran *et al.*, 2012). The direct matrix inversion method represents the most straightforward method (Rahma and Cho, 2010). The stripping method is often applied for Germanium detector and is based on successive subtraction of the Compton background from higher to lower channels. The folding iteration method is based on successive folding of better and better trial functions (Shustov and Ulin, 2015; Zech, 2013; Bandzuch *et al.*, 1997).

The performance of the NaI(Tl) scintillation detector based on the gamma-ray spectroscopy system is not satisfactory in retaining its original peak (which is delta like function) of various gamma ray spectrum. Survey of different literatures reveals that no work has been reported to use 200 by 200 direct matrices inversion method to convert measured mono-energetic and multi-lines gamma-ray spectra to retain its original peaks (Shustov and Ulin, 2015; Minato, 2014; Zech, 2013; Amandeep *et al.*, 2011; Arvind *et al.*, 2008). The main purpose of this work therefore is to use 200 by 200 direct matrices deconvolution method to unfold mono-energetic and multi-lines gamma-ray spectra measured using the NaI(Tl) scintillation detector so as to retain its original peak by restoring counts in the Compton continuum into their corresponding photo-peaks.

MATERIALS AND METHODS

Experimental Setup and Data Acquisition System

This study has made use of four identical cylindrical NaI(Tl) ORTEC 905-3 series detectors. The crystals are optically coupled to the PMT and encased in a light

tight aluminium case. The face of each detector had a diameter of about 5.08cm (“2 inches by 2 inches” crystal size). The detectors are attached to pre-amplifiers for maintaining the time constant of the pulse. The resolution of these detectors is about 7% for ^{137}Cs . They have light decay time of 230 nanoseconds, which is translated to a voltage pulse of rise time 0.5 microseconds. Each detector has 3 connectors at their rear, high voltage (HV), Anode and Dynode, which is damped by a 50-ohms resistor for this experiment (ORTEC, 2015). Both detectors are attached to the pre-amplifiers for maintaining the time constant of the pulse.

For convenience, all detectors were named with letter D1, D2, D3 and D4. Each detector was made to view the radioactive source such that each detector’s face was 5 cm away from the source as shown in Figure 1. All detectors were positively powered by a quad high-voltage power supply NIM module model RPH-012. Detector signals from each detector were passed through a linear split module, which had two outputs for each channel. From each channel, one signal was fed to the Analogue-to-Digital Converter (ADC; RPC-022 16ch CS) and the other signal was sent to the Leading-Edge Discriminating (LED) module. For each channel, one discriminated signal was fed into the coincidence unit, which was responsible for sending signals to the gate generator (KN1500) for triggering the event. The other discriminated signal from the same channel was delayed using a logic delay unit before being fed to the Time-to-Digital Converter (TDC; KC3781A). Trigger logic OR provide event triggering condition (Kumwenda, 2018). Figure 1 describes the complete data read out electronics deployed during experiment.

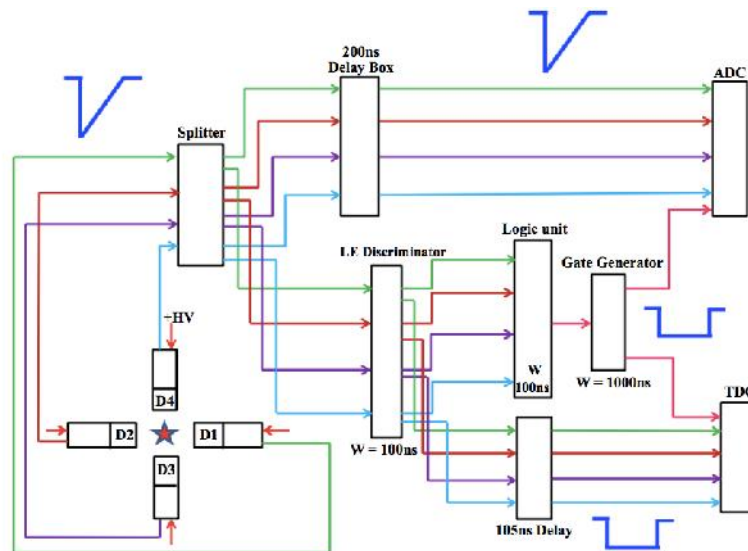

Figure 1: The electronic data readout circuit deployed for this experiment

THE DETECTOR RESPONSE FUNCTION

Direct Matrix Inversion Unfolding Method

The measured spectrum in physical experiment are usually distorted and transformed by different detector effects, such as finite resolution, limited acceptance, efficiency variations, perturbations produced by the electronic device, etc. To reproduce true photon spectrum from the measured distributions it is necessary to take into accounts these effects by means of the response function (Benitez *et al.*, 2008). Normally the response functions are obtained by response matrix. From the basic mathematical relationship, the measured spectrum $M(E)$ can be given as follows;

$$M(E) = R(E, E_0)T(E_0) \dots\dots\dots (1)$$

Where $T(E_0)$ is the original or true energy distribution of the gamma rays emitted by the source and $R(E, E_0)$ is the response function of the detector.

The task is to obtain the true gamma ray spectrum given the measured energy spectrum. Thus, the desired photon spectrum $T(E_0)$ is calculated from the

matrix equation as follows;

$$T(E_0) = R^{-1}(E, E_0)M(E) \dots\dots\dots (2)$$

Where $R^{-1}(E, E_0)$ is the inverse of the response matrix.

The pulse height distributions from various mono-energetic gamma ray spectra were obtained from the Monte Carlo simulation based on the Geant4 package using “2 inches by 2 inches” NaI(Tl) scintillation detector. During simulation, the dimensions of the “2 inches by 2 inches” NaI(Tl) scintillation detector were adapted from the manufacturer technical specifications. The geometry was modelled with the corresponding scintillation crystal with a case of 0.2 mm of aluminium. The space between the aluminium case and the crystal was filled with air (Cinel *et al.*, 2016). A glass window of 5 mm between the crystal and the PMT was also considered in this simulation, and the photomultiplier tube was modelled as a filled with air in the aluminium cylinder (Kumar *et al.*, 2009). A 0.5 mm thick aluminium housing, separated from the crystal by a very thin air gap, protects the photo-detector. The air thickness between the aluminium and the crystal as well as aluminium and the photomultiplier are 0.2 mm and 0.25 mm respectively (Cinel *et al.*, 2016; Kumar *et*

al., 2009). For systematic study the measured and simulated data were taken at the same number of events 1.4×10^6 for all chosen energies.

Simulation of Response Function

In this study, the Monte Carlo method based on the Geant4 package codes was used for formation of response matrix. For the formation of the response matrix, one might need more than 100 spectra depending on the dimension of the problem one dealing with, which is very time consuming and complicated work (Benitez *et al.*, 2008). To minimize the workload in making the response matrix, this study simulated 200 γ -ray's spectra ranging from 0.050 to 2.04 MeV with an interval of 10

keV as represented in Figure 2 in 2D. Z-axis of the 2D spectrum shows the peak to total ratios which gives the diagonal elements of the response matrix. The peak at 200 keV is due to the Compton backscattering due to the random direction of the gamma photons during simulation. The other peaks in y-axis are single and double escape peaks when the gamma photons reach a threshold of 1.02 MeV (Kumwenda, 2018). To acquire trustworthy results, the simulated response function must be determined with the same conditions as an actual experiment as shown in Figure 4. For the accuracy of the deconvolution method defined in equation (1), the response function $R(E, E_0)$ should have many energy points (Benitez *et al.*, 2008).

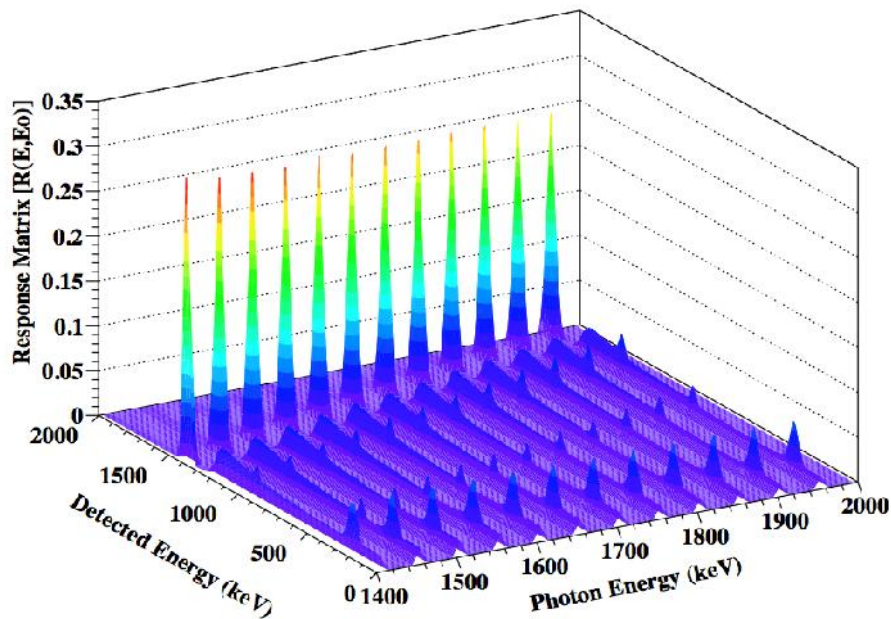

Figure 2: The matrix response function from the simulated mono-energetic gamma rays using NaI(Tl) scintillation detector

When a photon with energy E_0 is radiated there is a certain chance of being fully or partially detected. The probability that a photon of energy E_0 is detected with energy E is given by the response matrix $R(E, E_0)$ (Rahma and Cho, 2010). The response matrix gives the probability that a photon is detected. In order to obtain response matrix $R(E, E_0)$ it is important to

calculate Peak-to-Total ratio (P/T) (Rahma and Cho, 2010; Almaz and Cengiz, 2007). Figure 3 shows example of the calculated P/T ratios curve, which gives the diagonal elements of the response matrix. The response function was arranged as a row to form 200 by 200 response matrix. The obtained response matrix was inverted using ROOT V.5.4 program.

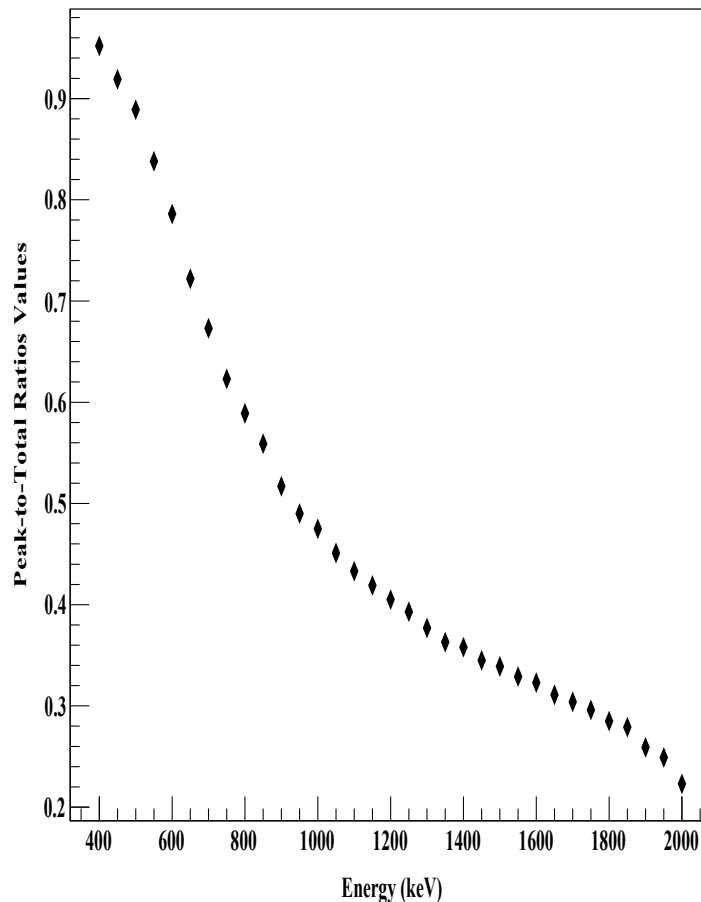

Figure 3: Example of peak to total ratios curve, which gives the diagonal elements of the response matrix

Deconvolution Procedures

In principle deconvolution methods can be divided into two groups specifically, direct and iterative. This study, presents brief description of the direct matrix inversion unfolding algorithm. The response matrices were arranged as a row and column to form N by N upper triangular response matrix. The obtained upper triangular matrices $N \times N$ were inverted using TMatrix class (`TMatrix::kInvert`) in the ROOT software. To obtain vector $M(E)$, the measured spectrum was integrated in 10 keV energy intervals. The multiplication of matrices R^{-1} and column vector M gives another column matrix T ,

which is the true gamma-ray spectrum of the detector. The acquired column vector T was filled in the histogram for plotting true energy spectrum from the measured spectrum.

Furthermore, the correctness of the response matrix was checked by multiplying R and R^{-1} and we have found that all elements along the diagonal are unity while in the inverse matrix all elements above the diagonal are negative numbers. These are physically justifiable. When measured spectrum (column vector M) is multiplied by the inverted matrix R^{-1} due to photons of a given energy the number of photons fall entirely in the

channel corresponding to the given energy in the true spectrum (column vector T). Since the diagonal elements are positive the above statement can be true only if all elements above the diagonal are negative (Subrahmanyam and Ammiraju, 1964).

RESULTS AND DISCUSSIONS

Validation of Experiment and Simulation

The accuracy of the response function is verified by the comparison with experimental measurements. Therefore, the comparison of the measured and simulated spectra done using radioactive standard gamma source of ^{137}Cs as

displayed in Figure 4. It is clear from Figure 4 that, there is a good agreement between the simulated and measured spectra around the photo-peak region but slight deviation is observed below 200 keV. The simulated and measured shows a peak at around 200keV that is caused by Compton backscattering. It is also observed that the simulated spectra show lower counts between Compton edge and photo-peak that might be caused by single Gaussian function for broadening. This study presents the results and discussions of the detector D1 only because the other three detectors (D2, D3 and D4) used for systematic uncertainty study and show similar results as D1.

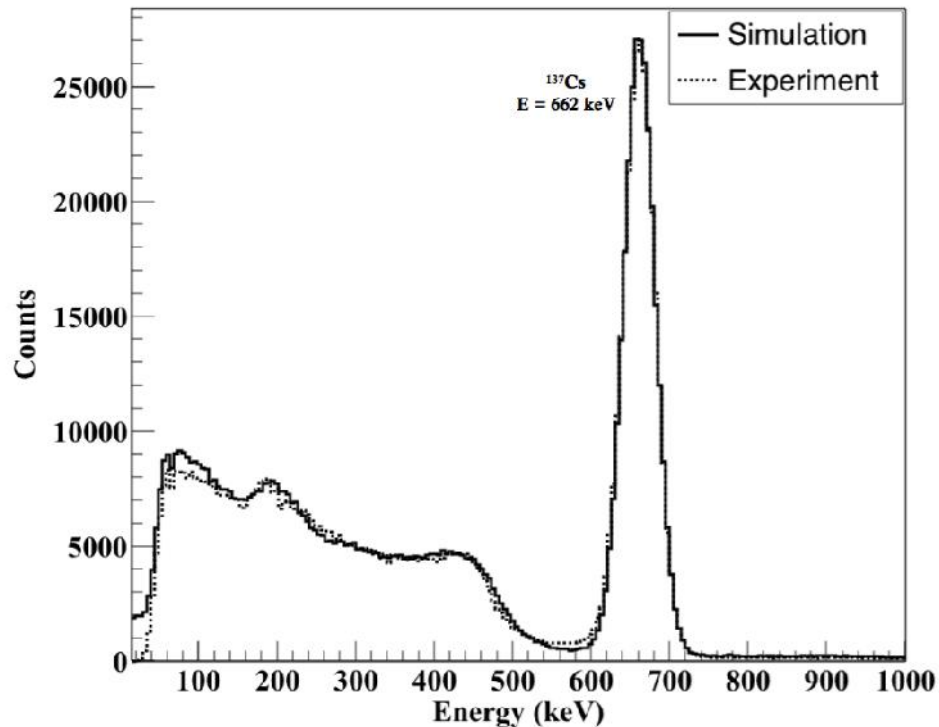

Figure 4: Comparison of the experiment and the simulation for the standard radioactive source ^{137}Cs with gamma ray energy of 662keV

Deconvolution of Mono-Energetic Source

The measured and deconvoluted gamma ray spectra are overlaid in Figure 5. By means of the direct matrix inversion unfolding method, the backscattered peak and Compton continuum are significantly

eliminated from the measured spectra into the corresponding photo-peak. To quantify the efficiency of the deconvolution technique the P/T ratio after applying direct matrix inversion unfolding method was calculated and was increased to 0.92 from 0.31 (0.61 increment) for ^{137}Cs radioactive source. Therefore, the number

of counts in the photo-peak region increased approximately by factor of 0.61

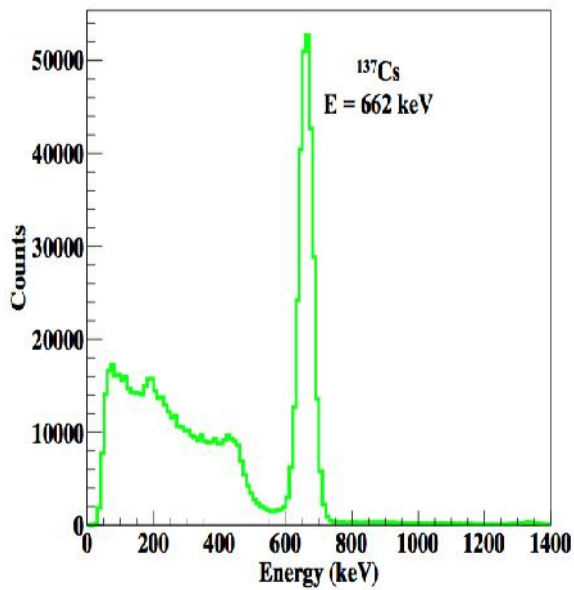

(a)

after deconvolution.

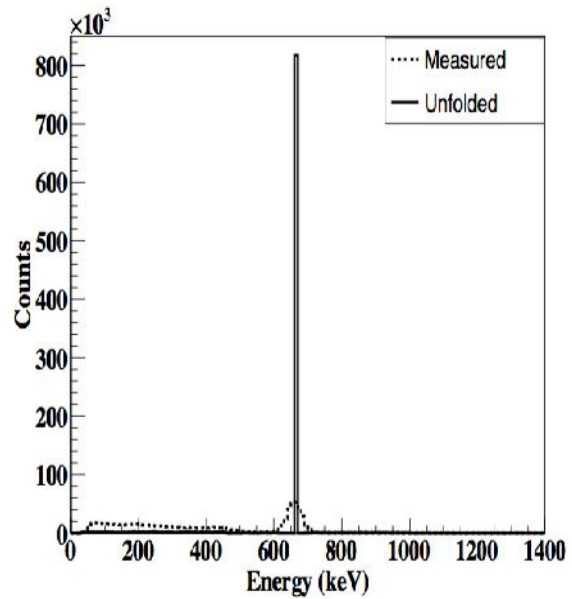

(b)

Figure 5: (a) Measured energy spectrum of ^{137}Cs (overlaid as green histogram) and (b) The deconvoluted (overlaid as black histogram) using matrix inversion method

Deconvolution of Multi-Lines Sources

Multi-line sources, ^{133}Ba and ^{60}Co were also used to confirm the trustworthiness of the deconvolution software. ^{133}Ba disintegrates by electron capture into two main $^{133}\text{Cs}^*$ excited levels of 437 keV (85.4%) and of 383 keV (14.5%). It follows then ^{133}Cs decays to its stable ground state by emitting gamma rays of

several energies as shown in the decay scheme of ^{133}Ba displayed in Figure 6 (Be *et al.*, 2008). The measured spectrum Figure 7(a) shows that 81 keV line populates much more than the 356 keV line, according to ^{133}Ba decay scheme 356 keV line has higher emission probability than 81 keV line. By the application of unfolding matrix, 356 keV gamma line of ^{133}Ba shows higher emission probability as expected.

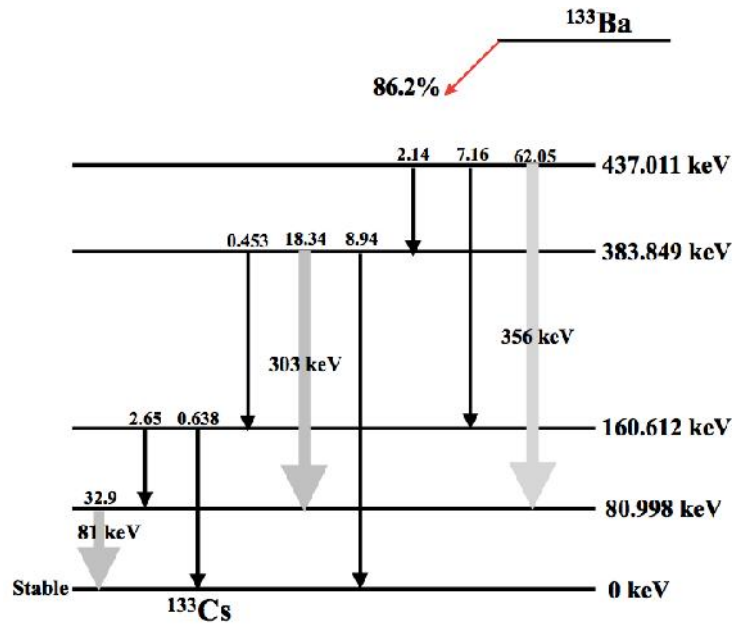

Figure 6: The decay scheme of ^{133}Ba , showing the several gamma lines. The gamma peaks observed from the experiment are 81 keV, 303 keV and 356 keV

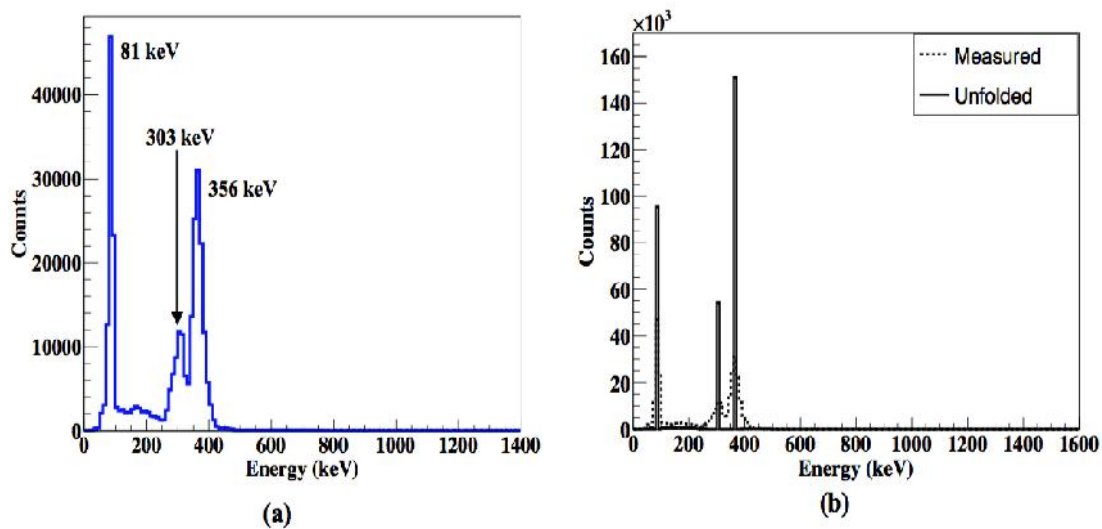

Figure 7: (a) The measured energy spectrum of ^{133}Ba (blue histogram) and (b) The deconvoluted spectrum (black histogram) using matrix inversion method

^{60}Co decays to ^{60}Ni via beta minus emission. The decay is initially to nuclear excited state of $^{60}\text{Ni}^*$ from which it emits either one or two gamma rays to reach a ground state of the ^{60}Ni isotope (Be *et al.*, 2008). The creation of ^{60}Ni by the beta minus emission of ^{60}Co is described by the decay scheme in Figure 8. It is known

that ^{60}Co has two gamma lines with almost the same probability of emission as shown in the decay scheme. However, as shown in Figure 9(a), 1.333 MeV line was measured to populate much less than the lower line. Deconvolution for ^{60}Co decay resulted in the almost same probability of emission as expected, as shown in Figure 9 (b).

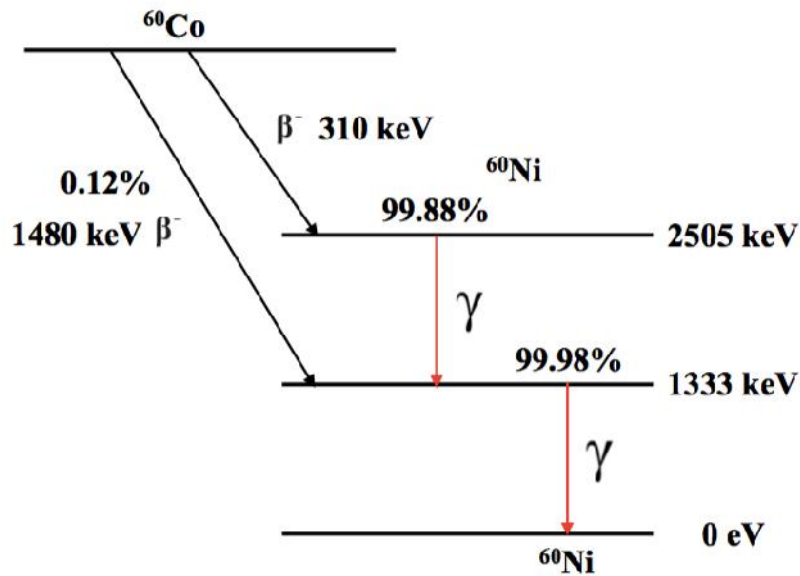

Figure 8: The decay scheme of ^{60}Co , showing the two gamma lines (1.172 MeV and 1.333 MeV) which has almost the same probability of emission.

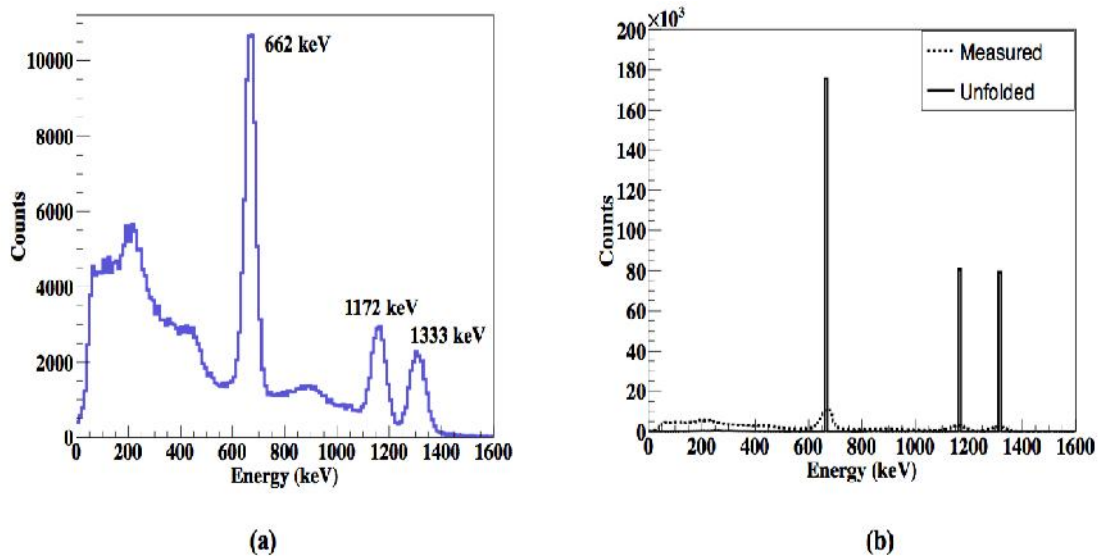

Figure 9: (a) The measured energy spectrum of ^{60}Co and ^{137}Cs (blue histogram) and (b) The unfolded spectrum (black histogram) using matrix inversion method.

Based on the unfolding results, the peak to total ratios (P/T) for three calibration radioactive gamma-ray's sources were calculated. The P/T ratio results obtained after application of the deconvolution method taken with three calibration sources with gamma-ray's energies of 81 keV, 303 keV and 356 keV (for ^{133}Ba), 662 keV (for ^{137}Cs), 1173 keV and 1333

keV (for ^{60}Co), were improved from (to) 0.50(0.90), 0.40(0.83), 0.57(0.93), 0.31(0.92), 0.18(0.84) and 0.15(0.83), respectively as shown in Figure 10. It should be noted also that the P/T ratio are almost one order of magnitude different between the maximum and the minimum. Moreover, it can be observed that the P/T ratios for all energy peak points were

improved after unfolding and the maximum increment P/T ratio appear at 1.333 MeV. It is also interesting to note

that the calculated P/T ratios in this work is significantly improved compared to the one reported by Rahma and Cho (2010).

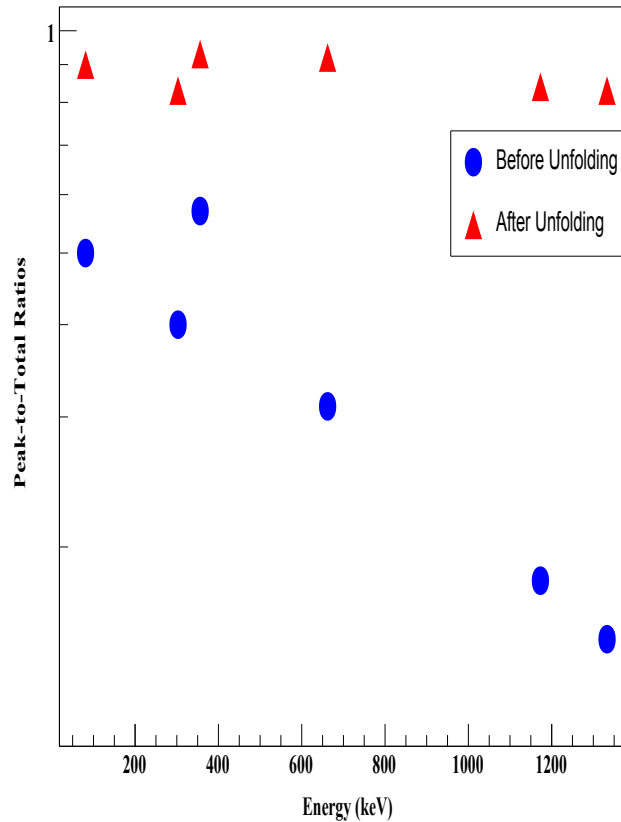

Figure 10: Peak-to-Total ratios before and after unfolding of three calibration radioactive sources

CONCLUSIONS

The main theme of this study, was to use 200 by 200 direct matrix inversion methods to convert measured gamma-ray spectrum using the NaI(Tl) scintillation detector into the photo-peak by restoring counts from the Compton backscattering and Compton continuum into their corresponding photo-peak. The Monte Carlo simulation based on the Geant4 package was conducted to study the response function of the NaI(Tl) scintillation detector and also for the formation of the 200 by 200 response matrices. The Compton backscattering and Compton continuum counts was significantly transferred into the

corresponding photo-peak and consequently the peak to total ratio was improved. The P/T ratio results obtained after application of the deconvolution method taken with three calibration sources with gamma-ray's energies of 81 keV, 303 keV and 356 keV (for ^{133}Ba), 662 keV (for ^{137}Cs), 1173 keV and 1333keV (for ^{60}Co), were improved from(to) 0.50(0.90), 0.40(0.83), 0.57(0.93), 0.31(0.92), 0.18(0.84) and 0.15(0.83), respectively. Furthermore, energy resolution for 662 keV peaks of ^{137}Cs improved to 3.5% (from 7.4%). The unfolding results also show that the spectrum retains its original shape which is delta like function. Also, by implementing inverse matrix unfolding algorithm the

results show a more precise identification of the spectrum as well as removal of electronics fluctuations in the measured spectrum. In conclusion, the unfolding method was successfully studied and best suited for the analysis of mono-energetic and multi-lines gamma ray spectra. Therefore, small peak can be identified and analyzed that would otherwise be lost in the background. As an extension of this study, comparison between direct matrix inversion method and iterative method is needed for systematic uncertainty study.

ACKNOWLEDGMENTS

The authors would like to acknowledge the support of the National Research Foundation of Korea and Korea University as well as the Department of Physics of the University of Dar es Salaam.

REFERENCES

- Almaz E. and Cengiz A. (2007). Deconvolution of Continuous Internal Bremsstrahlung Spectra of ^{32}P , ^{85}Kr and ^{143}Pr . X-Ray Spectrometry, X-Ray Spectrometry, 36(6): 419-423. <https://doi.org/10.1002/xes.1001>
- Amandeep S., Karamjit S., Bhajan S. and Sandhu B.S. (2011). Experimental Response Function of NaI(Tl) Scintillation Detectors for Gamma Photons and Tomographic Measurements for Defect Detection. Nuclear Instruments and Methods in Physics Research B, 269(3): 247-256. <http://dx.doi.org/10.1016/j.nimb.2010.09.004>
- Arvind D.S., Manpreet S., Bhajan S. and Sandhu B.S. (2008). Response Function of NaI(Tl) Detectors and Multiple Backscattering of gamma Rays in Aluminium. Applied Radiation and Isotopes, 66(10): 1467-1473. doi: 10.1016/j.apradiso.2008.03.006.
- Bandzuch P., Morhac M. and Kristiak J. (1997). Study of the Van Cittert and Gold Iterative Methods of Deconvolution and Their Application in the Deconvolution of Experimental Spectra of Positron Annihilation. Nuclear Instruments and Methods in Physics Research Section A, 384(2-3): 506-515. [https://doi.org/10.1016/S0168-9002\(96\)00874-1](https://doi.org/10.1016/S0168-9002(96)00874-1)
- Be M.M., Chiste V., Dulieu C., Browne E., Chechev V., Kuzmenko N., Kondev F., Luca A., Galan M., Pearce A. and Huang X. (2008). Table of Radionuclides, vol. 4. Monographie BIPM-5.
- Benitez J.Y., Noland J.D., Leitner D., Lyneis C., Todd D.S. and Verboncoeur J. (2008). High Energy Component of X-ray Spectra in ECR Ion Sources. In Proc. ECRIS'08, Chicago, IL, USA, paper MOPO-08: 77-84.
- Cinelli G., Tositti L., Mostacci D. and Bare J. (2016). Calibration with MCNP of NaI Detector for the Determination of Natural Radioactivity Levels in the Field. Journal of Environment Radioactivity, 155-156: 31-37. <https://doi.org/10.1016/j.jenvrad.2016.02.009>
- Hanka L. (2020). Deconvolution of Gamma Ray Spectra Using Singular Value Decomposition of Matrices. Land Forces Academy Review, 25(2): 136-145. DOI: [10.2478/raft-2020-0017](https://doi.org/10.2478/raft-2020-0017)
- Kiran K.U., Ravindraswami K., Eshwarappa K.M. and Somashekarappa H.M. (2016). Experimental Response Function of a 3" x 3" NaI(Tl) Detector by Inverse Matrix Method and Effective Atomic Number of Composite Materials by Gamma Backscattering Technique. Applied Radiation and Isotope, 111: 56-65. DOI: [10.1016/j.apradiso.2016.02.006](https://doi.org/10.1016/j.apradiso.2016.02.006)
- Kumar G.A., Mazumdar I. and Gothe D.A. (2009). Experimental Measurements and GEANT4 Simulations for a Comparative Study of Efficiencies of LaBr₃: Ce, NaI(Tl), and BaF₂. Nuclear Instruments and Methods in Physics Research Section A, 610(2): 522-529.

- <https://doi.org/10.1016/j.nima.2009.08.075>
- Kumwenda M.J. (2018). Measurements of Bremsstrahlung Photons in 28 GHz Electron Cyclotron Resonance Plasma, PhD Thesis, Korea University.
- Minato S. (2014). Spectrum Analysis of Gamma Rays Emitted from I-131 Using a Response Matrix for a 3" ×3" NaI(Tl) Scintillator. *Radiation Emergence Medicine* 3(1): 56-58. Corpus ID: 117952685
- Morhá M. and Matoušek V. (2011). High Resolution Boosted Deconvolution of Spectroscopic Data. *Journal of Computational and Applied Mathematics*. 235(6): 1629-1640. <https://doi.org/10.1016/j.cam.2010.09.005>
- ORTEC, "905-Series-NaI Scintillation Detectors," tech. rep., (2015). <http://www.ortec-online.com/-/media/ametektortec/brochures/905-series-nai-radiation-detectors.pdf>.
- Rahma M.S. and Cho G. (2010). Unfolding Low-Energy Gamma-Ray Spectrum Obtained with NaI(Tl) in Air Using Matrix Inversion Method. *Journal of Scientific Research*, 2(2): 221-226. DOI: <https://doi.org/10.3329/jsr.v2i2.4372>
- Subrahmanyam P. and Ammiraju P. (1964). An Analytical Method of Analysing Gamma-Ray Pulse Height Spectra. *Nuclear Instruments and Methods*, 33(1): 87-92. [https://doi.org/10.1016/0029-554X\(65\)90220-X](https://doi.org/10.1016/0029-554X(65)90220-X)
- Shustov A.E. and Ulin S.E. (2015). Matrix of Response Functions for Deconvolution of Gamma-Ray Spectra. *Physics Procedia*, 74: 399-404. doi: 10.1016/j.phpro.2015.09.210
- Zech G. (2013). Iterative Unfolding with the Richardson-Lucy Algorithm. *Nuclear Instruments and Methods in Physics Research Section A*, 716: 1-9. <https://doi.org/10.1016/j.nima.2013.03.026>