



Regular Research Manuscript

Situational Analysis of Gold Processing Practices at Artisanal and Small-Scale Gold Mining in Tanzania

Sospeter P. Maganga^{1†}, Ombeni J. Mdee¹, Godlisten G. Kombe² and Justin W. Ntalikwa¹

¹Department of Mining and Mineral Processing Engineering, College of Earth Sciences and Engineering, The University of Dodoma, P.O. Box 11090, Dodoma, Tanzania

²Department of Petroleum and Energy Engineering, College of Earth Sciences and Engineering, The University of Dodoma, P.O. Box 11090, Dodoma, Tanzania

[†]Correspondent author: engsocy@gmail.com; ORCID: <https://orcid.org/0000-0002-3058-4188>

ABSTRACT

This study reports the state-of-art situation of gold processing practices at artisanal and small-scale gold mining (ASGM) in Tanzania. It involved literature review, document review of public domain reports, and field survey during data collection. This was followed by screening of literature, reports, and field data relevant to the study topic. Further, the strengths, weaknesses, opportunities, and challenges (SWOC) analysis of ASGM was conducted and discussed. The study indicates that ASGM subsector in Tanzania continues growing with people involved directly in ASGM ranging between 1 to 1.5 million. Further, the study indicates that ASGM in Tanzania contributes about 90% of the total employment in the mining sector and contributed 30% of total gold production (42 tonnes) in the year 2020/2021. Furthermore, the average monthly revenue collection from mineral commodities in Tanzania has increased from TZS 1.7billion to TZS 7.06 billion after establishment of mineral markets. Moreover, the study indicates ASGM still employ inefficient processing methods such as hand crushing, sluicing with manually regulated water flow rate, and environmentally pollution gold recovery method such as amalgamation. Following this, a mercury free gold processing flowsheet was proposed subject for further investigation to reduce environmental impacts and improve gold recovery in ASGM. Also, the SWOC analysis identified the critical barriers for the maximum contribution of ASGM to the national economy of Tanzania, which need further attention by ASGM stakeholders.

ARTICLE INFO

Submitted: April 5, 2022

Revised: April 20, 2023

Accepted: April 30, 2023

Published: June 2023

Keywords: Gold processing practices, mercury free flowsheet, mineral demonstration centres, artisanal and small-scale gold mining, and SWOC analysis.

INTRODUCTION

The artisanal and small-scale gold mining (ASGM) subsector provides livelihood to many people in the world including Tanzania. This information is supported by Kinyondo and Huggins (2020) who

reported that ASGM in Tanzania contributes about 90% of the total employment in the mining sector. Moreover, in the year 2021, ASGM produced 30% of total gold production (42 tons) in Tanzania (URT, 2021). Globally, ASGM produces about 600 tons per year

which accounts 15-20% of the total annual gold produced (Heymann, 2020). On the other hand, the report by Mutagwaba *et al.* (2018) indicated that the total number of people in Tanzania involving directly in ASGM ranges between 1 to 1.5 million. At the global level, the number of people engaged in ASGM operations is estimated to be more than 20 million (Heymann, 2020) which is almost half of the 40.5 million people involved in all artisanal and small-scale mining (IGF, 2017).

Despite the mentioned contributions of ASGM to the URT and the government's efforts to formalize ASGM, the subsector is still faced with many challenges such as mercury pollution; limited access to geological information; limited access to affordable finance; inefficiency mining and processing technologies; child labour, and poor health and safety to workers (Mutagwaba *et al.*, 2018; Merket 2019).

Although there are many previous studies on ASGM in Tanzania such as Hiji and Maganga (2015), Mdee (2015), Ntalikwa (2015), Lema and Mseli (2017), Mutagwaba *et al.* (2018), Kinyondo and Huggins (2020), Tembo and Mdee (2022), just to name few; still there is limited information on strengths, weaknesses, opportunities, and challenges (SWOC) analysis of current gold processing practices of ASGM in Tanzania. The present study is aimed at reviewing the current situation of gold processing practices in Tanzania with a focus on the SWOC facing ASGM. The study will help

to increase awareness for stakeholders particularly on critical issues facing ASGM for growth and increased contribution of the subsector to the national economy.

METHODS AND MATERIALS

In this study, the methodological approach was adapted from Rweyendela and Kombe (2021) with minor modification on data collection techniques by adding a field survey as indicated in Figure 1. The data was collected through literature review, document review, and field survey on selected artisanal and small-scale gold mines as shown in Table 1. In literature review, past research studies conducted on small-scale gold mining in Tanzania were searched from reputable research databases such as Google Scholar and Scopus. The document review was conducted on public domain government reports such as parliamentary budget reports from the Ministry of Minerals as well as international agency reports such as Intergovernmental Forum (IGF) on Mining, Minerals, Metals and Sustainable Development and United Nations Environmental Programme (UNEP) as indicated in Table 2. The literature and reports were screened based on abstract and introduction relevant to the study topic. In field survey, current gold processes practices at ASGM were discussed. Finally, SWOC analysis was conducted, discussed and future direction provided.

Table 1: Artisanal and small-scale gold mines visited in this study.

S/N	Name	District-Region
1	Nholi small-scale gold mine	Bahi-Dodoma
2	Nyarugusu, Nyakagwe, and Musasa small-scale gold mines	Geita-Geita
3	D-reef, Kapanda, and Ibindi small-scale gold mines	Mpanda-Katavi
4	Itumbi small-scale gold mine	Chunya-Mbeya

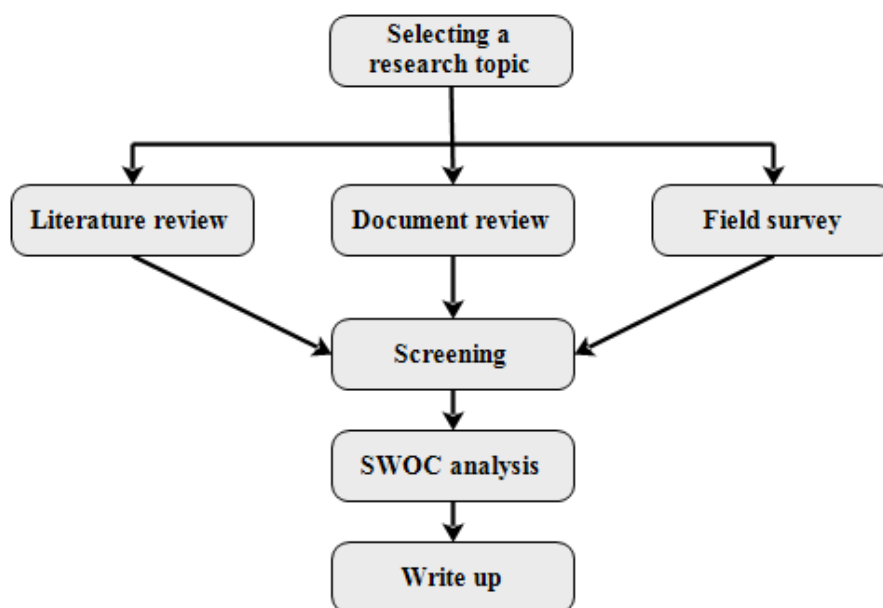

Figure 1: Methodological approach used in this study.

Table 2: Sample of documents reviewed in this study.

S/N	Name	Information	Type
1	Speech by the Minister of Minerals Hon. Doto Mashaka Biteko (MP.), presenting a revenue and expenditure estimates for the year 2019/2020, 2020/2021 and 2021/2022	Annual gold production at artisanal and small-scale gold mining	Parliamentary budget reports
2	Tanzania Mining Commission (TMC) annual report of 2018/2019	Revenues of mineral markets	TMC report
3	Tanzania Mining Act of 2010 and its amendment of 2017	Requirement for primary mining license	Mining Act
4	Analysis of formalization approaches in the artisanal and small-scale gold mining sector based on experiences in Ecuador, Mongolia, Peru, Tanzania and Uganda	Mercury free practices	UNEP report

Definition of Artisanal and Small-Scale Mining

Although the literature is inconclusive on the universal accepted definition of artisanal and small-scale mining (ASM); many researchers agree to differentiate between artisanal mining and small-scale mining as follows: artisanal mining is characterized by rudimentary operation; informal; intense labour; low level of skills;

low degree of mechanization; low levels of environmental, health and safety awareness; and often conducted for subsistence purpose (*i.e.*, feed family and pay bills). Whereas, small-scale mining can be rudimentary or conventional operation, formal, require low initial investment, with the size of operation less than 100,000 tpa run-of-mine ore (ROM) (Seccatore *et al.*, 2014; Mutagwaba *et al.*, 2018, Veiga and

Gunson, 2020). The ‘tpa’ means tons-per-annum.

Gold Occurrences Hosting ASGM in Tanzania

Gold occurs in nature mainly as native gold (< 20 mol% Ag) and as various alloy such as gold-silver (electrum, 20-80 mol% Ag), gold-copper and gold-tellurides, just to name few. Gold also occurs as sub-microscopic either as colloidal gold (*i.e.*, submicron gold inclusion in sulfide minerals) or solid solution gold (*i.e.*, gold atomically distributed in crystal structure of

sulfide minerals such as pyrite and arsenopyrite) and surface gold (*e.g.*, gold adsorbed onto carbonaceous particles) (Chryssoulis and McMullen, 2016). The major gold occurrences in Tanzania are associated with Archean and Proterozoic formations, which are grouped into five main geological regions. This includes Lake Victoria Gold Region (LVGR), Central Tanzania Gold Region (CTGR), East Tanzania Gold Region (ETGR), West Tanzania Gold Region (WTGR), and South Tanzania Gold Region (STGR) as indicated in Figure 2, (Merket, 2019).

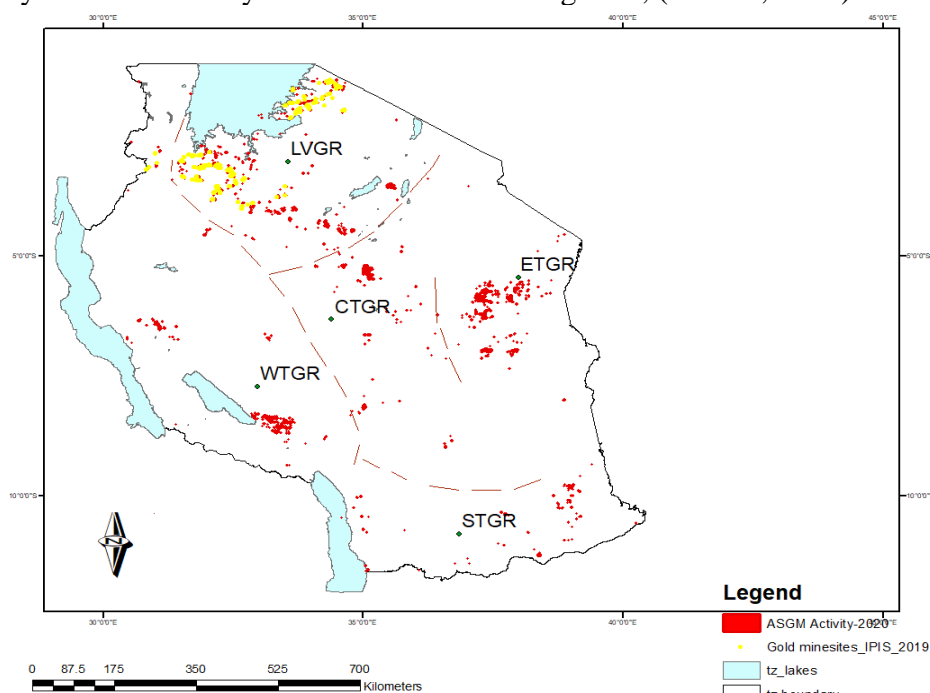

Figure 2: The map of Tanzania showing major ASGM sites (reproduced after Merket, 2019).

According to the Tanzania Mining Act of 2010 and its amendment of 2017, the owners of small-scale mining are required to possess primary mining licences (PMLs) to conduct their operations legally. Figure 3 indicate the number of PMLs issued annually to small-scale miners (*i.e.*, gold mining and other commodities) from 1999 to 2020 with the peak value occurred in 2013, thereafter started to decrease. One of the reasons may be introduction of new regulations which affected the small-scale industry sector. However, further investigation is required.

Gold Production from Small-Scale Mining in Tanzania

Since march 2019, gold produced from ASGM operations in Tanzania were traded through mineral markets located in most ASGM regions (TMC, 2019). The establishment of local mineral markets in Tanzania, benefits both small-scale miners and the government of the United Republic of Tanzania. This includes increase of income to small-scale miners due to selling of gold at regulated price, stimulate growth of small-scale gold mining, record keeping of gold sales from small-scale miners, increase in government revenues and

creation of employment (URT, 2020). Figure 4 indicates the contribution of small-scale gold mining to the total gold production in Tanzania. It can be observed that, the percentage of total gold production from small-scale mining has increased from 10% in 2012 to 30% in 2020. This may be attributed to the increase in the number of formal small-scale gold mining

operations in the country as well as effect of established mineral markets, which minimize smuggling of gold. Likewise, Figure 5 indicates that the average monthly revenue collection from mineral commodities in Tanzania has increased from TZS 1.7 Billion to TZS 7.06 Billion after establishment of mineral markets, (TMC, 2020b).

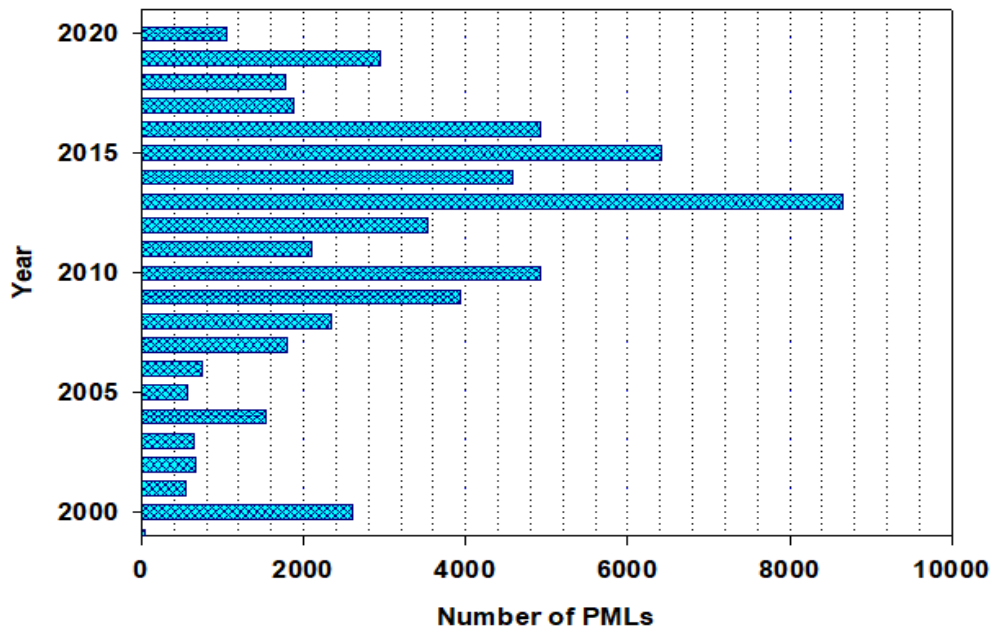

Figure 3: Number of primary mining licences (PMLs) issued by year (TMC, 2020a).

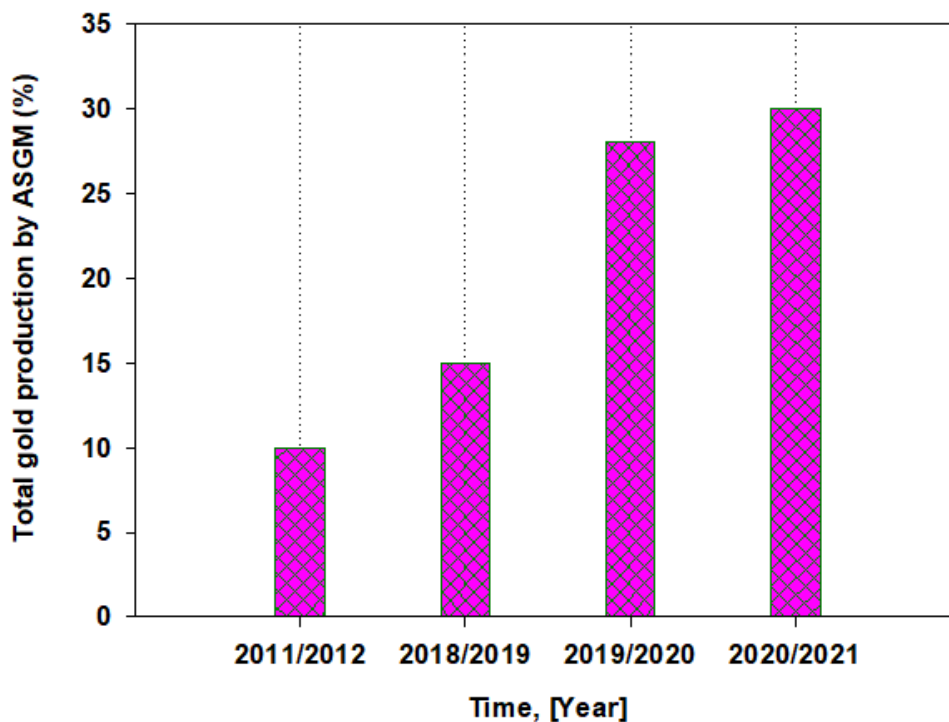

Figure 4: Contribution of gold production by small-scale mining in Tanzania (UNEP, 2012; URT, 2019; URT, 2020; URT, 2021).

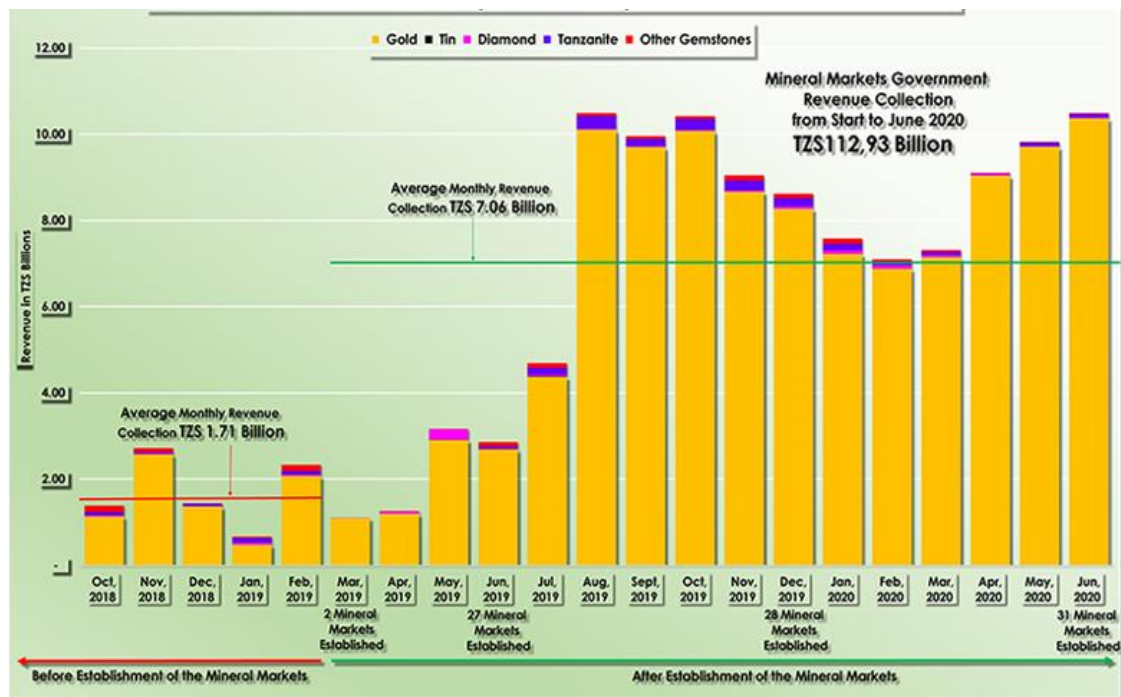

Figure 5: Monthly revenue collection before and after establishment of mineral markets in Tanzania (TMC, 2020b).

Gold Processing Practices by ASGM in Tanzania

The general flowsheet for ASGM has been constructed by the authors after site visits of several artisanal and small-scale gold mining in Tanzania as indicated in Figure 6. The flowsheet consists of several gold processing practices (stages) such as crushing (Hand crushing and Jaw crushing); grinding using ball mills; gravity concentration using sluicing tables; amalgamation of gold concentrates; burning of the produced amalgam; vat leaching of the gravity tailings; carbon adsorption of the leached gold; elution and electrowinning of the gold pregnant solution. The detail of each gold processing stage is presented in the next paragraphs.

Ore crushing

Ore crushing is the first stage of mineral processing which aims to reduce the size of mined-out ores for further downstream processes such as grinding. In Tanzania ASGM crushing operations are conducted

by hand crushing using hammers or mechanically by using jaw crushers. However, the hand crushing method dominates most ASGM sites in Tanzania. This was observed by authors in field visits at Nholi (Bahi-Dodoma); Itumbi (Chunya-Mbeya); Nyarugusu, Nyakagwe, and Musasa (Geita) in the year 2020 as well as at D-reef, Kapanda, and Ibindi (Mpanda-Katavi) in the year 2022.

A specific observation made in 2020 at the Nholi gold mine (Dodoma) indicated that hired men and women performed hand crushing using a sledgehammer (Figure 7a). Crushing a 25 kg ore bag was charged about TZS 700 for soft rock and TZS 1,000 for hard rock. An individual as shown in Figure 7(a) was estimated to crush 5 to 10 bags per day (maximum 250 kg ore per day). It was further observed that at the Nholi gold mine, boulders were crushed down to the size of 2.5-5 cm through the hand crushing method and 30 HP jaw crushers (Figure 7b) running on diesel engines, crushed 20 cm size rocks to about 2.5 cm.

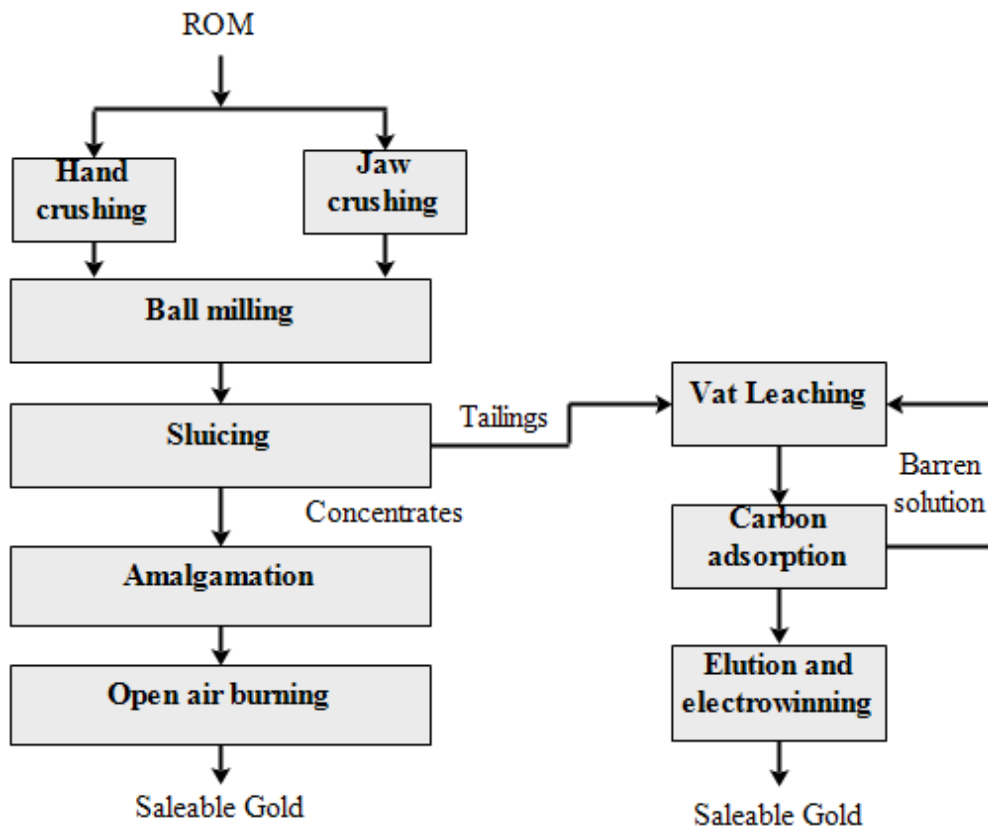

Figure 6: Current practices of gold processing at ASGM in Tanzania.



Figure 7: (a) Hand crushing (b) Jaw crushing operations at Nholi gold mine, Dodoma.

Ore milling

Ore milling is the second stage of mineral processing which aims to liberate the mineral of interest (*i.e.*, gold) from gangue minerals. In Tanzania’s ASGM operations, ore milling is often carried out through locally made ball mills. Locally fabricated ball mills are made from 25 to 40 mm thick steel shells and contain different sizes (Diameter x Length). Common sizes

observed at Nholi gold mine were small (\varnothing 84 x 85 cm), which took 3 ore bags of 25 kg each per batch; medium (\varnothing 105 x 80 cm, \varnothing 110 x 83 cm) which took 6 ore bags of 25 kg per batch; and large (\varnothing 120 x 105 cm) which took 12 ore bags of 25 kg each per batch. It was observed that at the Nholi gold mine, the charging of fresh grinding media was 300 steel balls for a small ball mill, 600 steel balls for a medium ball mill and 1200

steel balls for a larger ball mill. Further, it was observed that the average running time for a ball mill to complete a single batch operation was 60 minutes at 45 rpm. Another survey conducted at Musasa mine in 2020 showed that ball mills were of two sizes. A small ($\text{Ø } 99 \times 81\text{cm}$) mill took 2 ore bags of 25 kg each, and a large ($\text{Ø } 107 \times 96 \text{ cm}$), which took 4 ore bags of 25 kg each. The grinding time for Musasa ball mills was between 45-50 minutes. In

addition, an observation made by one of the authors in 2021 at the Itumbi small-scale gold mine (Chunya) indicated local ball mills were running at an average speed of 40 rpm. The similar speed of 40 rpm was observed at Kapanda (Katavi). Figures 8(a) and (b) indicate a typical example of a ball and hammer mills, respectively at surveyed sites.



Figure 8: (a) Ball mills at Nholi mine (b) A hammer mill in Chunya mine.

Sluicing

Sluicing is a common gravity mineral concentration method employed in ASGM operations in Tanzania. The main purpose of any mineral concentration method is to enrich the ore through the reduction of impurities (*i.e.*, gangue minerals). The field observations made at the Nholi gold mine indicated that the average length, width, and depth of sluice boxes were 290 cm, 55 cm and 4 cm, respectively as shown in

Figure 9. The inclination angle to horizontal was determined as 14° through trigonometric sine rule after measuring the length and height of the sluice table. Further, the carpet material was made up of a sisal mat with clothing material placed underneath. The measured slope angle at the Nholi gold mine was within the reported range (*i.e.*, between 5 to 15°) according to the study by Veiga and Gunson (2020).

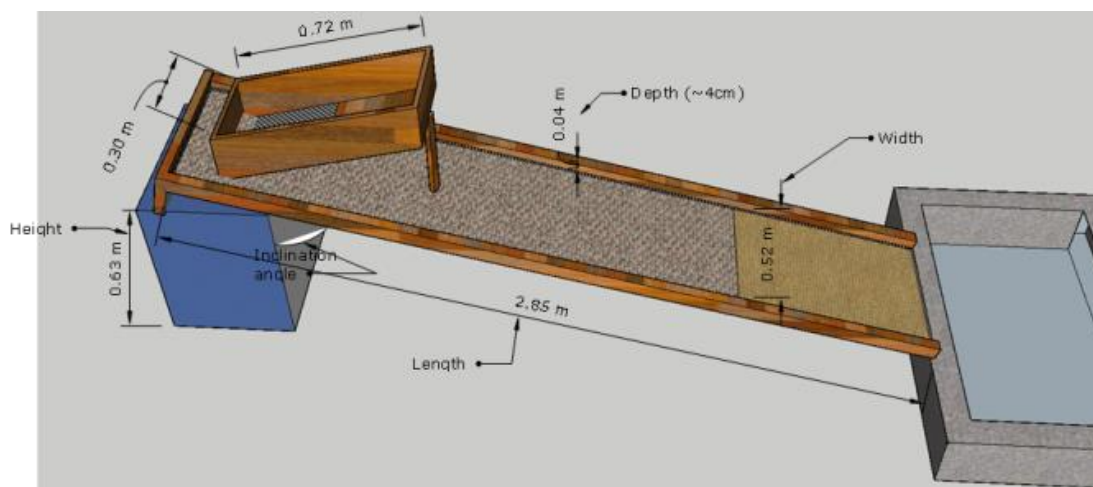

Figure 9: Typical features and dimensions of sluice table from Nholi gold mine.

The key features which determine the efficiency of the sluicing table include feed rate, water flow rate, particle size and shape, clean-up period (removal of concentrates), slope angle, riffles and carpets lining the sluice, width and length of the sluice, pulp density and arrangement of the sluices (Veiga and Gunson, 2020). Feed particle size, water flow rate, and slurry density are not effectively controlled in many ASGM operations in Tanzania and are one of the factors which contribute to gold losses at the sluicing tables. Veiga and Gunson (2020) reported that more than 90% of gold captured at the sluice table has a size between 75 μm and 500 μm . This implies that fine gold (*i.e.*, < 75 μm) and course gold (*i.e.*, > 500 μm) have a high chance of being lost during sluicing. The use of screens on the base of the sluice feed box is often considered critical for providing basic size screening of ore fed to the sluice table (Veiga and Gunson, 2020). However, it is effective on removing only boulders in the feed and not unliberated gold particles.

Amalgamation

Amalgamation is one of the old technology for gold recovery dated back to 1500 BC (Veiga *et al.*, 2006). In Tanzania, amalgamation technology is still used to recover gold from gravity concentrates in many ASGM operations. Wet gold concentrates are mixed with liquid mercury and panned for several minutes to produce gold amalgam. The gold amalgam is manually squeezed using a piece of cloth to remove part of the mercury. This is followed by open-air burning of gold amalgam using the charcoal stove to remove the remaining mercury in form of vapour and produce the sealable gold product. Veiga and Gunson (2020) reported that amalgamation is a cheap and efficient way to trap liberated gold particles often coarser than 200 mesh (74 μm). The authors further reported that manually squeezed amalgam usually contain 40-60% mercury. Figure 10(a) indicates the gold amalgamation process while Figure 10(b) shows produced gold amalgam ready for burning.

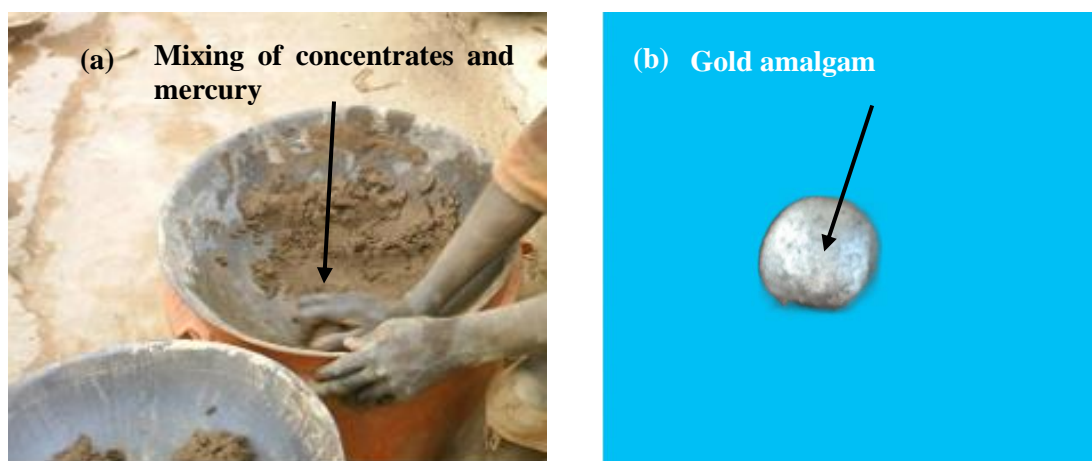

Figure 10: (a) Amalgamation process (b) A gold amalgam ready for burning.

VAT leaching and carbon adsorption

The ASGM operations in Tanzania use vat leaching technology to recover fine gold from sluicing tailings. The vat leaching process is considered cheaper than agitated tank leaching used by medium and larger scale mines since it can be locally constructed and operated in batch without

requiring continuous mixing of the slurry during the operation. However, the gold recovery in the vat leaching process is often less than 70% (Hiji and Maganga, 2015) compared to agitated tank leaching which can reach greater than 90% for free milling gold ores (Marsden and House, 2006). Moreover, the residence time in vat

leaching is longer (3 to 5 days) compared to agitated leaching (*i.e.*, 24 hours).

Vat leaching plants often consist of several components as follows: (1) a series of circular or rectangular tanks with connected PVC pipes, (2) carbon adsorption columns, and (3) mini-laboratory for measuring reagent concentration. Figure 11 indicate the simplified flowchart of a typical vat leaching plant in Tanzania. Gravity tailings are loaded into vat tanks and mixed with cyanide and lime as shown in Figure 12(a).

The usual concentration of cyanide is between 600 to 1000 ppm, slurry pH between 10 to 11, and residence time between 3 to 5 days at ambient conditions (Shamika 2015). In addition, the study by Ntalikwa (2015) observed that gold tailings from Chunya (Mbeya) contained coarser particle size (average particle size, P_{80} of 480 μm) which required further grinding to increase gold recovery in the vat leaching process.

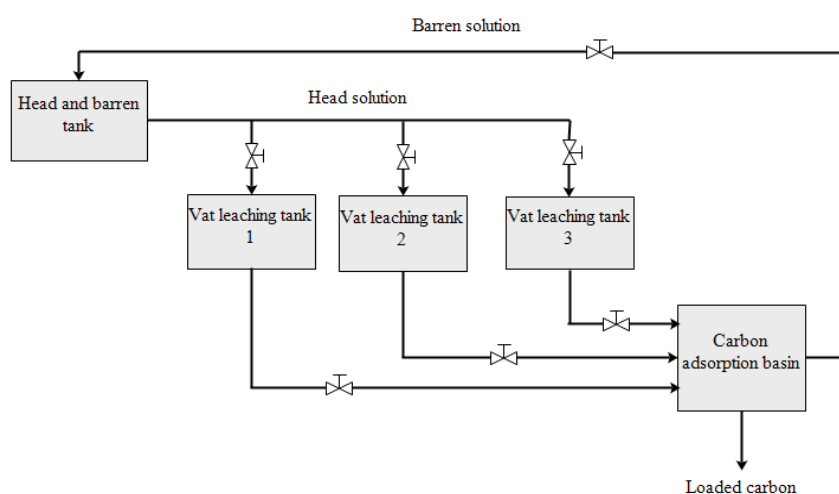

Figure 11: Typical flowchart of VAT leaching plant in Tanzania (Modified from Shamika, 2015).



Figure 12: (a) VAT leaching tanks and (b) Carbon adsorption columns.

The pregnant solution from vat leaching tanks is transferred to cemented adsorption columns filled with activated carbon for gold adsorption as shown in Figure 12(b). In the adsorption columns, regular mixing is required to ensure high adsorption

efficiency which is normally done by measuring the gold content in the barren solution. Most small-scale miners don't have a carbon stripping facility on-site hence loaded carbon is often transported to elution facilities located away from vat

leaching plants. The stripped carbon can be used up to 3 times before being discarded since there is no carbon regeneration

facility for small-scale mining (Shamika, 2015).

Elution and electrowinning

The purpose of elution is to strip gold adsorbed on activated carbon while electrowinning aims to recover gold from the Elution's pregnant solution to obtain cathode gold. Many ASGM in Tanzania uses integrated electrowinning and elution column for gold recovery. These are low-pressure inbuilt electrowinning-elution columns as opposed to high pressure and separate electrowinning elution columns used by other countries such as South Africa and Zimbabwe (Shamika, 2015). An integrated electrowinning and elution column used at a typical site in Tanzania operates at elevated temperature (95 to 98°C), pH above 12 and stripping solution containing 1% NaOH and 1% NaCN (Shamika, 2015). Moreover, the typical condition affecting the electrowinning process include applied current and voltage (e.g., 40 to 60 A and 3 to 5.5 V), the conductivity of eluate, pH, and concentration of metal ions in the solution. The plated gold on the cathode (steel wool) is often dissolved in sulphuric acid to form precipitates, which are dried by charcoal stove before being smelted with flux (borax and silica) to produce a sealable gold bar (Shamika, 2015).

Risk of mercury use at ASGM in Tanzania

The use of mercury for gold recovery at ASGM through amalgamation technology has health, safety and environmental risks to small-scale miners and the surrounding community. While the global mercury use in ASGM was estimated to be 1400 tpa (Appel and Na-Oy, 2012), the Minamata initial assessment survey done by the United Republic of Tanzania (URT) in 2016/2017 indicated that gold extraction with mercury amalgamation processes contributed to releasing mercury of 602 kg/annum to air; 520 kg/annum to water; and 642 kg/annum to land. The report also indicated that ASGM are the most affected subsector, where about 1.5

million people were estimated to be at mercury exposure risks, of which 20-30% were women including about 75,000 children (URT, 2017).

Another observation by Lema and Mseli (2017) indicated that the mean concentration of mercury from the soil samples at Nyarugusu was 25.45 mg/kg, which was above the maximum limit of 1 mg/kg, recommended by the United States Environmental Protection Agency (US EPA). Another study by Merket (2019) reported that with exception of whole ore amalgamation, the rest worst mercury use practices including open burning of amalgam; burning of amalgam in residential areas; and cyanide leaching of amalgamated tailings without first removing the mercury were widespread in ASGM in North West regions of Tanzania (Geita, Shinyanga, Kigoma and Mara).

Proposed mercury free gold processing flowsheet for ASGM

Following the environmental pollution derived from the use of mercury in many ASGM in Tanzania; the mercury free gold processing flowsheet is proposed based on case studies conducted in Senegal and Peru (UNEP, 2018) as shown in Figure 13. The flowsheet involves comminution (i.e., size reduction with the aim of liberating gold particles), two stage gravity concentration (in order to achieve high grade of gravity concentrate), followed by gold recovery from concentrates through either direct smelting or intensive leaching. Conversely, the gold remaining in gravity tailings is recovered through the conventional vat leaching technology. The proposed gold processing flowsheet for ASGM, has benefits of eliminating mercury pollution and improving gold recovery. From the proposed flowsheet in Figure 13, potential areas which require further studies include two stage gravity concentration, direct smelting, and intensive leaching of gravity concentrates with

environmentally friendly reagents because of change in ore mineralogy (Senegal/Peru to Tanzania).

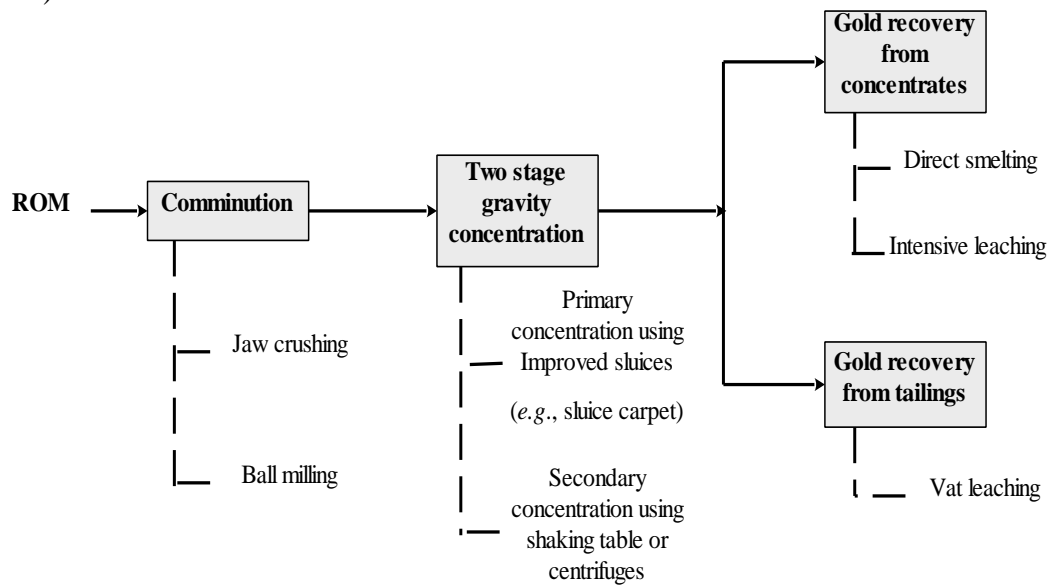

Figure 13: Proposed mercury free gold processing flowsheet for ASGM subject for further investigation.

Stakeholder intervention for gold processing practices at ASGM in Tanzania

Several key interventions have been implemented in Tanzania to introduce cleaner and improved technologies in ASGM as follows: application of retorts, application of borax smelting, and establishment of mineral demonstration centres.

Application of retorts

The United Nations Industrial Development Organization (UNIDO) on the global mercury project in Geita demonstrated the use of retorts during amalgamation to minimize the impact of mercury to the environment (UNIDO, 2007). The field observation by authors at visited sites indicate limited use of retorts by artisanal miners and amalgam is still burned in an open air.

Application of borax smelting

Field tests of borax smelting of gravity concentrates from sluicing was demonstrated by Appel and Jonson (2010) at Itumbi and Londoni ASGM sites. However, the uptake of this technology is still limited probably due to

requirement of high-grade concentrates (at least 3% Au) and low performance on sulfide ores (Veiga and Gunson, 2020).

Establishment of mineral demonstration centres

In Tanzania, several mineral demonstration centres for gold processing have been established at Katente (Bukombe), Lwamgasa (Geita) and Itumbi (Chunya) at the total cost of 4.3 billion Tanzanian shillings (URT, 2021). The centres are in operation and used to provide training to artisanal and small-scale miners as well as gold processing services at typical cost of 20 million Tanzania shillings for 100 tonnes of ore with grade of at least 4 g/t Au. However, the capacity of these plants is low (typically 1-2 tph) to handle material from nearby communities.

The field visit in the year 2022 by one of the authors at Itumbi mineral demonstration centre indicate the main processing equipment present include jaw crusher, closed circuit ball mill with hydrocyclone, 12 carbon in pulp (CIP) tanks, elution facility and mini-laboratory (containing pulveriser, sieve shaker, laboratory jaw crusher, hammer mill

and AAS machine). The jaw crusher produces 30 mm product size which is feed to the ball mill, the ball mill has the capacity of 1-2 wet tonnes per hour with the trommel screen of 1 mm. The 12 CIP tanks had the capacity of 1-1.2 tonne each, arranged in series and are equipped with inter-tank screens that prevent carbon movement from one tank to another, while the slurry move from one tank to another by gravity. The compressed air is introduced into the CIP tanks to provide agitation as well as source of oxygen for leaching reaction. The operation of CIP is semi-batch with total retention time of 30-32 hours and total carbon loading of 300 kg in 12 CIP tanks. Figure 14 (a) and (b) indicate ball mill and CIP tanks at Itumbi mineral demonstration centre, respectively.

The elution facility at Itumbi mineral demonstration centre has capacity of treating 500 kg of loaded carbon per batch. For 500 kg of carbon, 1 bag (25 kg) of sodium hydroxide in mixed with water and circulated through heater for 4 hours until the temperature reach 90°C before switching on the transformer for current flow to the electrowinning cell. Normally elution is conducted at a current of 30-35 mA and temperature around 118-120 °C for 24 hours.

SWOC Analysis for ASGM in Tanzania

The ASGM operations in Tanzania has various strengths, weaknesses, opportunities and challenges (SWOC). For example, TEITI (2022) reported that typical critical problems facing ASGM in Tanzania include lack of information about orebodies, inefficiency mining and mineral processing technologies, limited access to capital and operating funds, inadequate access to reliable markets particularly for industrial minerals, poor knowledge of record keeping such as operating costs and production data and limited training for development of ASGM. It is worth noting that the government of the United Republic of Tanzania has made efforts on market barriers for gold and gemstones by establishing 39 market centres at various regions in Tanzania (e.g., in Geita and Chunya) (URT, 2021).



Figure 14: (a) Ball mill (b) CIP tanks at Itumbi mineral demonstration centre.

However, still there is market barriers for industrial minerals (TEITI, 2022). Furthermore, the rest problems still persist, which need initiatives from stakeholders. Another study by Merket (2019) indicated that children with age less than 15 were engaging directly in ASGM operations in most of the surveyed sites. Moreover, the authors observed that mercury pollution and poor access to sanitation facilities was a common problem in surveyed ASGM. In addition, the study by Mutagwaba *et al.* (2018) indicated that child labour employment mainly in crushing and sluicing is another challenge facing ASGM. Other reported challenges were poor management of waste rocks and tailings, lack of mine closure plan, loss of minerals due to inefficient mining and processing technologies and lack of exploration operations.

Apart from the weaknesses and challenges of ASGM, Kinyondo and Huggins (2020) reported that Tanzania has advanced government formalisation policies in the East Africa region. The authors also reported that the established centre of excellence at some ASGM has started indicating potential benefits such as capacity building in terms of training for small-scale miners and gold processing services. These findings are in good agreement with the parliamentary report by the United Republic of Tanzania (URT) through Ministry of Minerals in 2021/2021 which indicated that 864 small-scale miners were trained at Katente, Lwamgasa, and Itumbi mineral demonstration centres and 11.6 kg of gold were produced in the

mentioned centres (URT, 2021). Further, the strengths of current gold processing practices at ASGM include simplicity of the process, low cost and easily adopted by unskilled people. Other strengths are the availability of mineral resources across various regions in Tanzania and the availability of an institutional framework for the formalization of small-scale mining operations which has increased over the past decade. Figure 15 indicate the summary of SWOC analysis in the present study. It is worth noting that, the development of the ASGM subsector requires full integration of all components in SWOC analysis through various stakeholders initiatives.

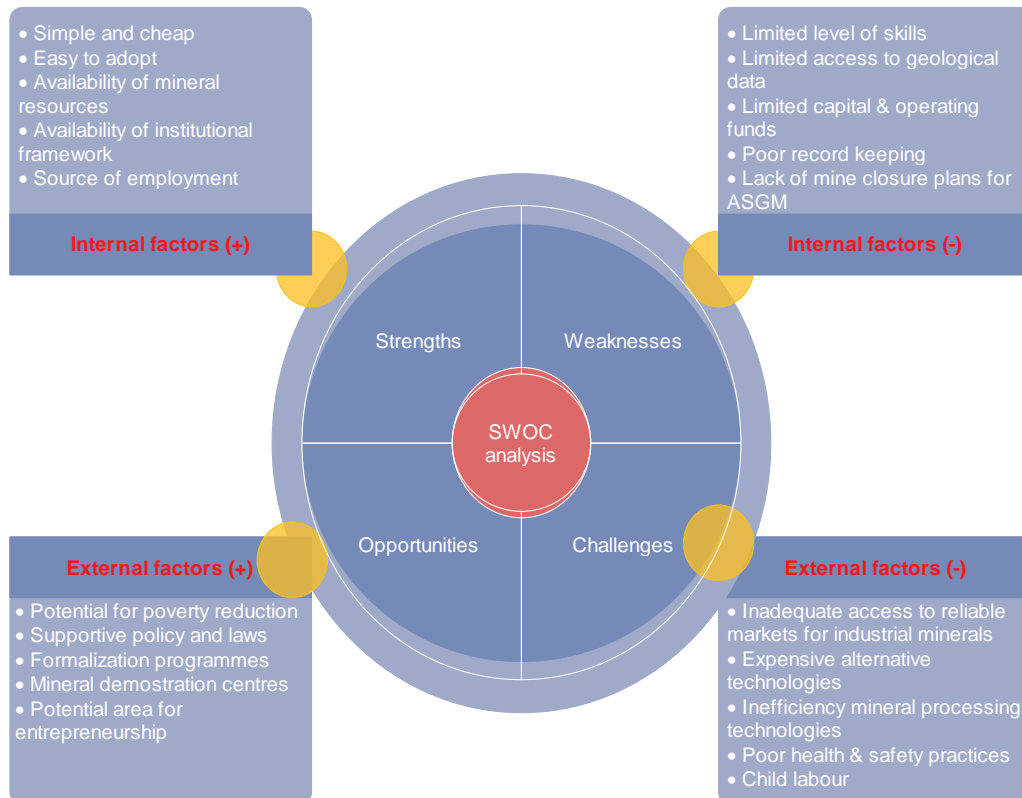

Figure 15: Summary of strengths, weaknesses, opportunities and challenges (SWOC) for gold processing practices at ASGM in Tanzania.

CONCLUSIONS

The present study reports the state-of-art situation of gold processing practices at artisanal and small-scale gold mining (ASGM) in Tanzania, and provides the following key conclusions:

- There is no universal accepted definition of artisanal and small-scale mining.
- ASGM in Tanzania are distributed in several regions namely, Lake Victoria Gold Region (LVGR), Central Tanzania Gold Region (CTGR), East

- Tanzania Gold Region (ETGR), West Tanzania Gold Region (WTGR), and South Tanzania Gold Region (STGR).
- c) Both free-milling gold ores (e.g., at Nholi, Dodoma), complex gold-copper ores (e.g., at Mpanda Mineral Field) and refractory ores (e.g., Matandani and Kukuluma, in Geita) are found in Tanzania.
 - d) ASGM operations in Tanzania contributed 30% of total gold production in 2020/2021.
 - e) The average monthly revenue collection from mineral commodities in Tanzania has increased from TZS 1.7 Billion to TZS 7.06 Billion after establishment of mineral markets.
 - f) ASGM in Tanzania still employ inefficient processing methods such as hand crushing, sluicing with manually regulated water flow rate, and environmentally pollution gold recovery method like amalgamation. Therefore, a mercury free gold processing flowsheet was proposed to reduce environmental impacts and improve the gold recovery at ASGM.
 - g) Established mineral demonstration centres are beneficial to small-scale miners through provision of training and mineral processing services as well as enhance government revenues through collection of processing fees. However, these centres were not designed for providing community services due to low capacity (typically 1-2 tph).
 - h) Several issues as shown in Figure 15 have to be addressed to have a maximum contribution of ASGM to the national economy. For example, the issue of limited access to geological information and affordable access to finance, just to name few, remain critical for ASGM.

ACKNOWLEDGEMENTS

The authors would like to thank The University of Dodoma for financial support of

this study through Junior Academic Staff (JAS) training programme. The small-scale gold mining sites surveyed are also acknowledged.

Conflicts of Interest: The authors declare no conflict of interest.

REFERENCES

- Appel, P. W. and Jónsson, J. B. (2010). Borax—an alternative to mercury for gold extraction by small-scale miners: introducing the method in Tanzania. *GEUS Bulletin*, **20**: 87-90. DOI: <https://doi.org/10.34194/geusb.v20.4988>
- Appel, P. W. and Na-Oy, L. (2012). The borax method of gold extraction for small-scale miners. *Journal of Health Pollution*, **2**(3): 5-10.
- Chryssoulis, S. L. and McMullen, J. (2016). Mineralogical investigation of gold ores. In M. D. Adam, *Gold Ore Processing - Project Development and Operations* (pp. 57-93). Amsterdam, Netherlands: Elsevier.
- Heymann, T. (2020). Tackling the Challenges of the Interface Between Large-Scale and Artisanal and Small-Scale Mining. planetGOLD. Available online at <https://www.planetgold.org/tackling-challenges-interface-between-large-scale-and-artisanal-and-small-scale-mining>. Retrieved on 21st April 2023.
- Hiji, M. F. and Maganga, S. P. (2015). Application of response surface methodology for optimization of vat leaching parameters in small scale mines: Case study of Tanzania. *American Journal of Engineering, Technology and Society*, **2**(2): 21-25.
- IGF-Intergovernmental Forum on Mining, Minerals, Metals and Sustainable Development. (2017). *Global Trends in Artisanal and Small-Scale Mining (ASM): A Review of Key Numbers and Issues*. Canada: Winnipeg: IISD. Available online at <https://www.iisd.org/sites/default/files/publications/igf-asm-global-trends.pdf>. Retrieved on 14th August 2021.

- Kinyondo, A. and Huggins, C. (2020). 'Centres of excellence' for artisanal and small-scale gold mining in Tanzania. *The Extractive Industries and Society*, **7**(2): 758-766. DOI: <https://doi.org/10.1016/j.exis.2020.03.011>
- Lema, M. W. and Mseli, Z. H. (2017). Assessment of soil pollution (heavy metal) from small scale gold mining activities: A case of Nyarugusu gold mines, Geita–Tanzania. *International Journal of Environmental Monitoring and Protection*, **4**(1): 1-5.
- Marsden, J. O., and House, C. L. (2006). *The Chemistry of gold extraction*. Colorado, USA: SME.
- Mdee, O. J. (2015). Potential of artisanal and small-scale gold mines for economic development in Tanzania: A review. *Journal of Geology and Mining Research*, **7**(2): 11-18.
- Merket, H. (2019). *Mapping artisanal and small-scale mining in northwest Tanzania: A survey on its nature, scope and impact*. International Peace Information Service (IPIS). Available online at <https://ipisresearch.be/publication/mapping-artisanal-small-scale-mining-northwest-tanzania>. Retrieved on 17th October 2021.
- Mutagwaba, W., Tindyebwa, J. B., Makanta, V., Kaballega, D. and Maeda, G. (2018). *Artisanal and Small-Scale Mining in Tanzania–Evidence to Inform an Action Dialogue*. London: IIED. Available online at <https://www.iied.org/16641iied>. Retrieved on 15th June 2022.
- Ntalikwa, J. W. (2015). Gold recovery by cyanide leaching: A case study of small scale miners in Tanzania. *American Journal of Engineering, Technology and Society*, **2**(6): 162.
- Rweyendela, A. G. and Kombe, G. G. (2021). Institutional influences on circular economy: A Tanzanian perspective. *Sustainable Production and Consumption*, **26**: 1062-1073. DOI: <https://doi.org/10.1016/j.spc.2021.01.013>
- Seccatore, J., Veiga, M., Origliasso, C., Marin, T. and De Tomi, G. (2014). An estimation of the artisanal small-scale production of gold in the world. *Science of the Total Environment*, **496**: 662-667. DOI: <https://doi.org/10.1016/j.scitotenv.2014.05.003>
- Shamika, G. C. (2015). *Vat Leaching and Elution Plant Technology Manual*. Dar es Salaam, Tanzania. Available online at <https://www.academia.edu/31439791>. Retrieved on 6th June 2021.
- TEITI-Tanzania Extractive Industries Transparency Initiative (2022). Final report on carrying out scoping study on small scale mining for the purpose of including the sub-sector revenue disclosure through the Tanzania Extractive Industries Transparency Initiative. Available online at <https://www.teiti.go.tz/publications/scoping>. Retrieved on 21st April 2023.
- Tembo, M. M. and Mdee, O. J. (2022). Analysis of Ore Hand-Crushed Size Distribution for Grinding Process in the Artisanal and Small-Scale Gold Mines Production: A Case Study of Nholi Mine, Bahi District. *Tanzania Journal of Engineering and Technology*, **41**(4): 95-105. DOI: <https://doi.org/10.52339/tjet.v41i4.763>.
- TMC. (2019). *Tanzania Mining Commission annual report 2018/2019*. Dodoma: Ministry of Minerals.
- TMC. (2020a). *Mining Licences Information*. Available online at <https://www.tumemadini.go.tz/pages/mining-licences-information>. Retrieved on 25th January 2022.
- TMC. (2020b). *Performance of Mineral Markets*. Available online at <https://www.tumemadini.go.tz/pages/performance-of-mineral-markets>. Retrieved on 10th February 2022.
- UNEP. (2018). *Illustrated guide to mercury free artisanal and small scale gold mining*. United Nations Environmental Programme. Available online at <https://indd.adobe.com/view/a9b3c39e-e7b7-412a-9d12-5cf47f484e56>. Retrieved on 28th June 2023.

- UNIDO. (2007). *Removal of Barriers to Introduction of Cleaner Artisanal Gold Mining and Extraction Technologies: Project EG/GLO/01/G34*. Vienna: Global Mercury Project. Available online at <http://archive.iwlearn.net/globalmercuryproject.org/countries/tanzania/docs/Tanzania%20Final%20Report.pdf>. Retrieved on 7th August 2021.
- URT. (2017). *Minamata Initial Assessment in Tanzania*. Dar es Salaam: Vice President's Office. Available online at <http://www.mercuryconvention.org/Portals/11/documents/MIAs/Tanzania-MIA-2017.pdf>. Retrieved on 20th May 2021.
- URT. (2019). *United Republic of Tanzania Parliamentary speech of honourable Doto Mashaka Biteko, minister of minerals reporting to the parliament the budget estimate for the financial year 2019/2020*. Available online at <https://www.parliament.go.tz/budget-list>. Retrieved on 17th October 2021.
- URT. (2020). *United Republic of Tanzania Parliamentary speech of honourable Doto Mashaka Biteko, minister of minerals reporting to the parliament the budget estimate for the financial year 2020/2021*. Available online at <https://www.parliament.go.tz/budget-list>. Retrieved on 17th October 2021.
- URT. (2021). *United Republic of Tanzania Parliamentary speech of honourable Doto Mashaka Biteko, minister of minerals reporting to the parliament the budget estimate for the financial year 2021/2022*. Dodoma: Ministry of Minerals. Available online at <https://drive.google.com/file/d/1O2VzF2e77YCwJ0c1gudcoHXqWoZlqn50/view>. Retrieved on 20th November 2021.
- Veiga, M. M. and Gunson, A. J. (2020). Gravity Concentration in Artisanal Gold Mining. *Minerals*, **10**(11): 1026. DOI: <https://doi.org/10.3390/min10111026>.
- Veiga, M. M., Metcalf, S., Baker, R. F., Klein, B., Davis, G., Bamber, A., . . . Singo, P. (2006). *Manual for Training Artisanal and Small-Scale Gold Miners*. Vienna, Austria:
- GEF/UNDP/UNIDO Global Mercury Project: Available online at <https://iwlearn.net/resolveuid/fe84adcc030ee07813d8278fdb4b790>. Retrieved on 17th October 2021.